

## **ON THE METROLOGY OF BIRKA AND EARLY SIGTUNA – TOOLS OF TRADE IN THE VIKING AGE LAKE MÄLAREN VALLEY (SWEDEN)**

### **THE STUDY OF ARCHAEOMETROLOGY**

Ancient weights represent a twofold source value for archaeological interpretation. On one hand we can draw conclusions based upon morphology; on the other we can retrieve information about the weight system employed at the site of recovery (given that we are able to recreate their original mass), which in turn provides important clues for interpreting trade relations. Because of the distinctively practical purpose of weights as tools in crafts and trade, it is possible to get a glimpse of a more pragmatic side of ancient society than what is commonly possible with other archaeological artefacts. It is hard to conceive of any reason why a choice of weight system should have been based on other than practical and mathematical grounds; the main governing factors being credibility and compatibility. Credibility – since using well-known and widely applied units of measurement provides a familiar nomenclature within which an exchange may be negotiated, reducing the risk of friction through misunderstandings. Compatibility – giving the parties the option to verify that the weights in use are of the correct mass, i. e. reducing the possibility for fraud. Further support for the importance of credibility and compatibility in measuring systems can be found in the need of precise measures in metallurgical crafts. Skewed proportions in an alloy, for instance bronze, might easily lead to a useless product. Weighing is also part of the cupellation process in determining the purity of noble metals. Because of this, weights are common finds in contexts connected to metallurgical activities (Ny Björn Gustafsson, pers. comm. April 2012; see e. g. Östergren 1989, 183 fig. 171).

For people of preindustrial societies, metrology would have been the primary language dictating how land was to be distributed and sown, the resulting produce sold, itineraries drawn up, alloys forged, houses built and taxes paid. Thus, units of measurement would have been applied in many aspects of everyday life, as well as economic and political life, and it is difficult for us today to fully appreciate their former pervasiveness throughout society.

The study of archaeometry is a field of statistical and historical research on an archaeological material. The mathematical patterns revealed by statistical methods in the Scandinavian material would be very confusing without the framework given by decrees, laws and contracts from areas and periods with a more advanced level of bureaucracy. The historical sources from Viking Age Scandinavia (rune stones) are unfortunately mute on this subject, so without historical sources from other areas, the link to the Caliphate would probably never have been discovered. With this material, scholars have been able to reconstruct piece by piece the design of the weight system of the Baltic Sea region (**fig. 1**) around the 10<sup>th</sup> century.

### **A NEW WEIGHT SYSTEM FOR THE BALTIC SEA TRADE THEATRE**

Accepting the factors put forth above on credibility and compatibility, it follows that traditional weight systems would only reluctantly be replaced. And it also follows that a transition, once called for, would

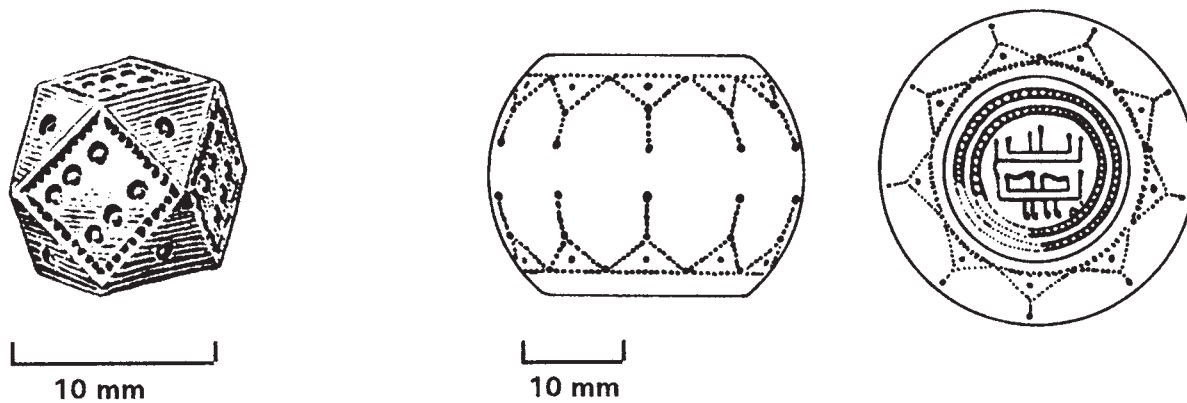

**Fig. 1** The Baltic Sea region with the locations of the *emporium* mentioned in the article. – (Map J. M. Schultzén).

have spread rapidly throughout the affected trade network in order to uphold an acceptable base for trade, especially in a pronounced weight economy. In the second half of the 9<sup>th</sup> century such a transition swept through the Baltic Sea region (Steuer 1987a, 462; Sperber 1996, 104f.). Over a time period of probably no more than a few decades a new weight system was adopted in an area spanning the Volga Bulgars in the east and certainly as far as Haithabu (Kr. Schleswig-Flensburg/D) and Kaupang (fylke Vestfold/N) in the west.

This new system originated in the Caliphate and was based upon the silver weight unit dirham and the gold weight unit mitqal (Hinz 1970, 2), but it was not the actual system of the Caliphate that was introduced straight off, but rather a local version (referred to below as the Baltic Sea system). Its metrological design was adapted to local preconditions and exhibited its own distinct morphology; characterised by the bipolar spheroid and cubooctaedral weights (**fig. 2**). Production of both weight-types was local, supported by traces of manufacturing from Gotland as well as Birka and Sigtuna (both sites in Stockholms län/S) (Östergren 1989, 171 f.; Gustin 1997, 163; Söderberg 1996, 12; 2008, 99 ff.). The impression of a compatible but yet separate system is further reinforced by the absence of Arabian weights around the Baltic Sea.

The incentives for this change are clear considering the dominance of Islamic coins in the contemporary numismatic material. Employing this weight system, that with some adaptations was valid in an area stretching from Samanid Persia, across Eastern Europe and furthermore up to the Baltic Sea region, facilitated long-distance trade and is in itself a hint as to how extensive these contacts must have been. Estimates totaling 50-100 million Islamic coins imported to the Baltic Sea region have been suggested (Noonan 1990, 255). In Western Europe however, where direct contacts with the heartland of the Caliphate were scarcer, but also as a consequence of the local money economy, the traditional Gallo-Romanic system was retained. Its roots



**Fig. 2** Representation of the cubooctaedral and bipolar spherical weights used within the proposed Baltic Sea system from the late 9<sup>th</sup> century. – (After Steuer 1973, figs 1-2).

can be traced via the Greeks back to the dawn of metrology in Egypt and perhaps even earlier. Still today it provides the foundation for the pound and ounce system (Roman *libra* and *uncia*). The Islamic system certainly shared the same roots, but had its direct origins in the somewhat modified Byzantine system (Sperber 1996, 55).

At the time of the introduction of the Baltic Sea system in the late 9<sup>th</sup> century the trade routes to the Caliphate seem to have shifted. During the 9<sup>th</sup> century the imported coins had been minted mainly by the Caliphs of the Abbasid dynasty, but from the early 10<sup>th</sup> century Samanidic coins dominate the material. The Samanids were officially subjects to the Caliph in Bagdad, but were in reality to sovereign rulers over today's Iran and extensive parts of Central Asia. The silver seems mainly to have reached Scandinavia by caravan to the Volga Bulgar region from where it passed on to Northern Europe (Kilger 2007, 240). Trading parties from Gotland might have been the first to establish contact with the Samanids via the Volga Bulgars, since the start of import of Samanidic coins to the island has been dated to approx. 905 AD, which is the earliest *terminus post quem* for the Baltic Sea region (Kilger 2007, 241). We cannot say whether the intermediaries on the Volga bend were exclusively Volga Bulgars or Scandinavians. We have in the travel accounts of Ibn Fadlan, an envoy of the Caliphate to the Volga Bulgars in the early 10<sup>th</sup> century, very vivid descriptions of the rituals of the Rus as an indication of Scandinavian traders in the area (Frye 2006, 63 ff.). It seems unlikely though that this foreign element would have been able to establish a monopoly on this trade, especially as the local population also employed a version of the Islamic weight system and even minted coins imitating the currency of the Caliphate (see Rispling 1990).

The link to the so-called Volga Bulgars becomes particularly clear when comparing weights from that area with their Scandinavian counterpart. The bipolar spherical weights are practically identical in the two regions and both adhere, possibly with some adaptations, to the weight system of the Caliphate with the *mitqal* as standard unit (Pritsak 1998, 35). On early bipolar spherical weights from Scandinavia there are in some cases pseudo-Islamic inscriptions, interpreted by Gert Rispling as imitations of the early Volga Bulgaric minting (G. Rispling, pers. comm. December 2008; Sperber 1996, 101), which as mentioned above had its origin in the minting of the Caliphate. A recurring legible word on these imitations is »bakh«, Arabic for first-class or *prima*, possibly with the purpose of reinforcing the image of the owner as well-connected and trustworthy (Fernstål 2008, 68 ff.).

Finds of cubooctaedral weights are on the other hand scarce in the former Volga Bulgar region, where the lesser units instead seem to have been represented by cubical weights (see Valeev 1995, 93), but the cubooctaedral form element has been associated with the Volga Bulgars and may have been chosen as a

reaffirmation of this relationship (Gustin 2004, 323; cf. Hårdh 2007). At Birka, cubooctaedrical weights have been discovered in layers dating to c. 860 AD (Gustin 2004, 312 f.), which is a few decades earlier than the present dating of the bipolar spherical weights, so it is possible that they initially were used separately. This is supported by the lack of this type of weight in the Caliphate and among the Volga Bulgars (Gustin 2004, 320). The implementation of the new weight system has for both regions been dated to the late 9<sup>th</sup> century (Sperber 1996, 103 ff.), possibly a bit earlier for Scandinavia as it has been suggested that the Volga Bulgars might have adopted this system as a part of the package when converting to Islam c. 900 AD (Pritsak 1998, 35), even if the logical conclusion based on geography and principles of diffusion would be that they should have received these influences first, being closer to the origin.

The manner in which the Baltic Sea system spread around the Baltic Sea has not been studied in detail, however in Birka the earliest date for the bipolar spheroid weight has been set to the late 9<sup>th</sup> century (see discussion Kuhlberg 1980; Steuer 1987a; Sperber 1996; Gustin 2004), thus it is possible that the influences extended from the Lake Mälaren Valley. On the other hand, as mentioned above, the trade in Samanidic silver seems to have been established by Gotlanders first, not reaching Birka until a few decades into the 10<sup>th</sup> century (Kilger 2007, 235 ff.), which would serve as an argument against a proposed diffusion with the Lake Mälaren Valley as a local epicentre. This needs to be researched further.

The rapid diffusion and the dominant position gained by this largely uniform idiom and metrology during the 10<sup>th</sup> century show how important it was to have a single system for the weight economy of the Baltic Sea trade theatre. The closest parallel to this event would be the adoption of the metric system a thousand years later and, since weight units were used to express economic value, it could even be regarded as a sort of early monetary union. Whether the change was enforced politically or adopted freely by each *emporion* we do not know. It has been suggested that there ought to have been a supra-regional trade organisation behind this; a Scandinavian/Slavonic precursor to the Hanseatic league (Steuer 2012, 200 ff.). Others propose instead a more advanced bureaucracy and subsequently more developed central powers in the region than what is commonly thought (Gustin 1997, 174 ff.; Schultzen 2009, 29). One does not necessarily exclude the other as regional differences and changes in preconditions over time could provide support for either interpretation. The author agrees that the rapid adoption of the Baltic Sea system does suggest the existence of a supra-regional trade organisation, but when the dirham import ended in the second half of the 10<sup>th</sup> century this organisation may very well have been substantially weakened, leaving local rulers with the challenge to rekindle trade by their own accord; the minting and production of weights in Sigtuna possibly representing an attempt to establish a royal control. Preceding and contemporary sources from influential regions support the notion that decisions on metrology were very much a political prerogative; its execution subject to extensive control and with harsh penalties for any attempts at cheating.

For instance, in the »Book of the Prefect« of 10<sup>th</sup>-century Byzantium it states that »any grocer who has weights or measures [which] do not bear the seal of the Prefect [...] shall be flogged, shaved and exiled« (Vikan / Nesbitt 1980, 11 f.).

The emperor Constantine instructed a representative of the public treasury on the proper way of handling the balance scale; by the top of its suspension cord with two fingers; »the remaining three fingers shall be free and extend towards the tax receiver, and no finger shall exert pressure on the weights« (Vikan / Nesbitt 1980, 29 f.).

In chapter 15 of Justinian's Novel 118 from 545 AD it states: »We order that those who collect public taxes shall use honest weights and measures, in order that they might not harm our taxpayers in this manner. But if taxpayers believe that they have suffered harm in respect to either weights or measures, they shall have freedom to receive, on one hand, measures and weights from the glorious prefects for the weighing of taxes in kind and, on the other hand, weights from the current count of the imperial largesses (the count of imperial expenditure)

for the weighing of gold, silver and other metals [...] these measures and weights are to be kept for safeguarding in the most holy church of each city« (Vikan / Nesbitt 1980, 31 and references cited therein).

On Scandinavian weights we usually see geometric patterns which probably not only served as decorative information. The mass of a newly cast weight may be calibrated downwards by grinding away some excess metal, but once that is done, a shallow stamped pattern may very well have served as a protection (if not perfect) against further manipulation. The number of dots in the pattern also show the place of the weight within a given set and is therefore not directly linked to actual mass (Steuer 1987b, 499f.).

## THE METROLOGY OF BIRKA IN THE LATE PERIOD (9<sup>TH</sup>-10<sup>TH</sup> CENTURY)

Using the CAD method for archaeometrological analysis to digitally reconstruct the volume and mass of the often badly corroded artefacts (see Schultzén 2011), 13 weights found during excavations in the »Black Earth« and the »Garrison« of Birka have been studied. This method has been shown to produce an adequate result without having to expose the artefacts to the potential hazards of the traditional method for calculating density (i. e. measuring the displacement of the object in water or sand). The generally accepted limit set for ascribing a weight to a certain unit in archaeometrological analysis is a <2 % deviation of the reproduced mass from the proposed target mass (Sperber 1996, 64).

Of the weights presented in **table 1**, two of them do not seem to fit the proposed standard unit. The reasons for this could be that they do not belong to this system, but more likely it is due to inaccuracies in either the manufacturing or the reconstruction analysis as the deviation still is quite low.

As a stand-alone analysis (**tab. 1**) the results indicate the existence of two mutually convertible systems in parallel. One being the standard weight system of the Caliphate based upon the silver weight dirham and the gold weight mitqal. The other and more numerous unit being the convertible version of  $19/20^{\text{ths}}$  (Sperber 1996, 83 ff.) or possibly  $15/16^{\text{ths}}$  (Schultzén 2009, 20 ff.; 2011, 2386) of a mitqal, i. e. the Baltic mitqal (the archaeometrological analysis presented in **tab. 1** is based upon the assumption that the Baltic mitqal represented  $19/20^{\text{ths}}$  of the Islamic mitqal, i. e. 4.0g). The author has previously interpreted this as possibly being part of a system designed to extract some sort of fee or tax by using one system for import and the other for export, effectively producing a  $1/20^{\text{ths}}$  or  $1/16^{\text{ths}}$  margin, paid for instance to the lord of the *emporium* for keeping a garrison as protection (see Schultzén 2009). Similar systems were practised in contemporary European money economies, such as England and the Holy Roman Empire, where obsolete coins had to be exchanged into new at a set rate, leaving a profit for the mint lord (Dolley / Metcalf 1961, 156). A dual weight system in Birka might have been the weight economy's answer to the same need. However, it is also possible that the Islamic mitqal weights simply were used when trading with merchants from regions where the Baltic mitqal would not have been valid. This would be supported by the fact that the Islamic mitqal is widely outnumbered by the Baltic mitqal (cf. **tabs 1-2**). On the other hand, most of the cuboctaedrical weights have been interpreted as Islamic dirham weights (see Sperber 1996), which would contradict such a conclusion.

On the subject of dirham weights, interestingly, in Scandinavia the mitqal and its derivatives dominate the weight material, which seems inconsistent with its intended use as a weight unit for gold. Somewhere along the road it seems the purpose of the mitqal changed to weighing silver, as objects and coins of gold are rare finds in comparison with silver. Either that or we need to consider a much larger import of gold than the archaeological material gives evidence for. But why then would the dirham weights be so light in comparison? Payment in silver would surely demand heavier weights as the amount needed for a transaction would be considerably greater. Nor can we simply say that the mitqal was a universal unit for valuable

ID	current mass (g)	reproduced mass (g)	proposed standard unit (g)	proposed multiple	proposed target mass (g)	deviation (%)
AFL 14580	1.58	1.58	0.8	2	1.60	-1.35
AFL 14311	2.08	2.32	0.8	3	2.40	-3.23
AFL 14223	2.35	2.43	0.8	3	2.40	1.36
AFL 14151	2.28	2.67	2.67	1	2.67	0.15
AFL 14577	4.36	4.74	0.8	6	4.80	1.23
SHM 14837:3	11.27	11.83	4.0	3	12.0	-1.30
SHM 34000:Bj740	11.40	12.94	4.23	3	12.69	1.93
AFL 14405b	14.34	15.97	4.0	4	16.0	-0.06
AFL 14405a	22.55	24.61	4.0	6	24.0	2.71
SHM 14563:15	31.66	31.58	4.0	8	32.0	-1.16
SHM 13838	39.57	40.04	4.0	10	40.0	0.26
AFL 14099	38.89	40.50	4.0	10	40.0	1.41
AFL x308 y201 LII	80.96	80.96	4.0	20	80.0	1.36

**Tab. 1** Archaeometrological analysis of 13 weights from the »Black Earth« and the »Garrison« at Birka (Stockholms län/S). – Unacceptable deviation in *italics*.

ID	current mass (g)	reproduced mass (g)	proposed standard unit (g)	proposed multiple	proposed target mass (g)	deviation (%)
Hum 3: 101550/1550	4.76	4.74	0.8	6	4.80	-1.27
Hum 3: 103227/3226	31.43	31.93	4.0	8	32.0	-0.06
Prof 1: 15017	8.12	8.13	4.0	2	8.0	1.77
Prof 1: 11001	20.80	24.72	4.0	6	24.0	3.15
Prof 1: 14509	8.54	8.46	4.23	2	8.46	0.00
Prof 1: 13404	2.67	2.68	2.67	1	2.67	0.53
Prof 1: 13049	1.58	1.59	0.8	2	1.6	-0.86
Prof 1: 2392	27.79	31.44	4.0	8	32.0	-1.57
Guldet 1	21.80	25.2	4.23	6	25.38	0.53
Guldet 3	29.96	41.08	4.23	10	42.30	2.27
Guldet 4	22.60	25.77	4.23	6	25.38	1.50
Guldet 5	25.65	32.06	4.0	8	32.0	0.27
Guldet 6	25.83	31.56	4.0	8	32.0	-1.22
Guldet 8	29.53	35.15	4.23	8	33.84	3.66

**Tab. 2** Analysis of eight weights from the excavations in Sigtuna (Stockholms län/S) of the city blocks »Professorn« and »Humlegården 3« as well as a reanalysis of six weights from the city block »Guldet«, previously analysed by E. Sperber (Sperber 1996, 88ff.). – Unacceptable deviation in *italics*.

metals in Scandinavia. What would then be the purpose of the dirham weights we also find in Scandinavian contexts? These unresolved questions will be studied further in forthcoming articles.

## THE METROLOGY OF EARLY SIGTUNA (10<sup>TH</sup>-12<sup>TH</sup> CENTURY)

At the time of the founding of Sigtuna the import of Islamic silver coins had all but ceased. In fact, this probably was a major contributor to the demise of Birka (see Landgren 1999; Schultzén 2004). Interestingly, the decline in import of Samanidic silver coincides with the conquest of Afghanistan and Khurasan by

**Fig. 3** 3D representation of the weight Hum 3:103227/3226 from the excavation of »Humlegården 3« at Sigtuna (Stockholms län/S), deposited c. 1050-1065 AD. – (3D model J. M. Schultzén).

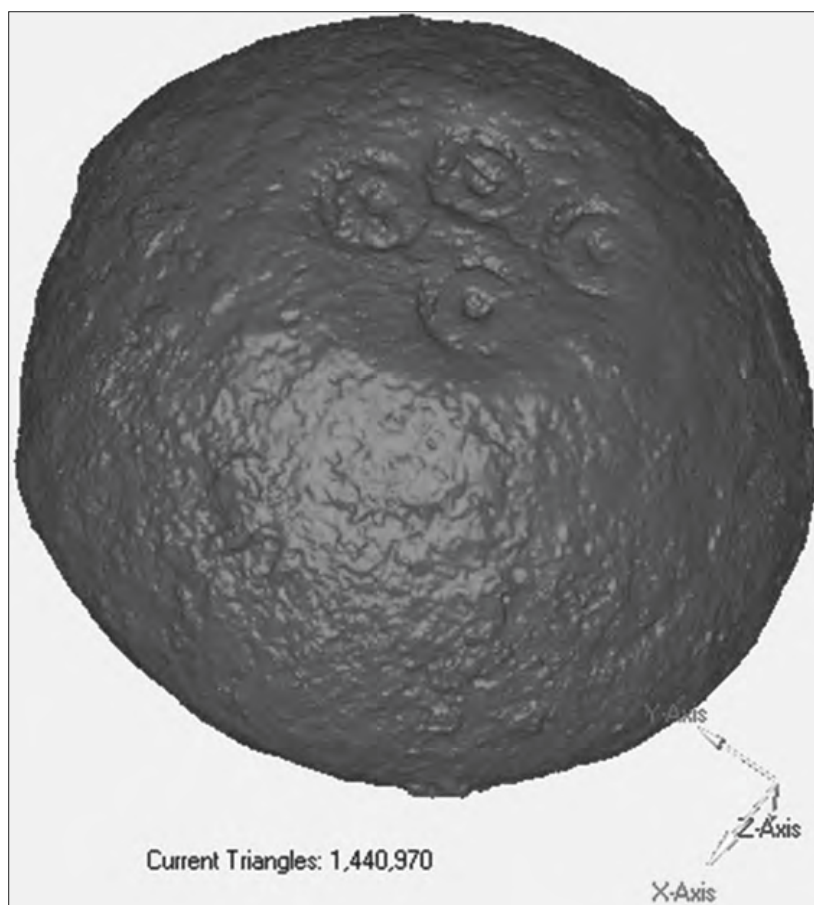

Alptigin, founder of the Ghaznavid dynasty (Lapidus 2002, 114f.). It has been suggested that the bulk of the Samanidic silver came from this region (Noonan 2000-2001, 153). This decline in minting would be a parallel to the situation that arose in the second quarter of the 9<sup>th</sup> century, when a conflict of succession in the Caliphate resulted in a sharp reduction of minting (Noonan 1986, 154f.; Rispling 2004, 29). Thus, with the founding of Sigtuna there would have been an opportunity to establish a new weight system adapted for the shift in trade towards Western Europe (cf. Brather 2010, 145f.). According to the principles for choosing a weight system outlined above, it would seem practical to have switched to the Gallo-Romanic system for the purpose of facilitating trade with these regions.

In his dissertation Erik Sperber analysed six weights from Sigtuna using Holm's method (Holm 1987, 205ff.) and came to the conclusion that they used a standard unit of c. 3.19 g. This is however not a unit known from any other established weight system, which would imply a very isolationistic policy for the new *emporium* and a shift in paradigm compared to Birka. It is also inconsistent with the archaeological material from Sigtuna which points to continued long-distance relations, albeit with a shift westward in geographical focus (Schultzén 2005, 27f.).

In the analysis of eight Sigtuna weights the author found that seven of these artefacts could be attributed to the Baltic Sea system (tab. 2), i.e. the same as was used in Birka, the remaining weight falling closely outside the 2 % deviation limit (Sperber 2004, 64).

A closer look at the individuals in this population reveals that they represent an extensive period of time. The weight Prof 1:15017 from the excavation of the city block »Professorn« was found in a late 10<sup>th</sup>-century context, making it the earliest of the population, while the latest (Prof 1:2392) was discovered in a 13<sup>th</sup>-14<sup>th</sup> century context (Anders Wikström, pers. comm. April 2009). Of course, this only sets the *terminus*

*ante quem* for their manufacture, so it is not possible to draw any conclusions on the metrology of later medieval Sigtuna from this alone. Remaining weights from the city block »Professorn« were all found in contexts belonging to the first half of the 11<sup>th</sup> century (Anders Wikström, pers. comm. April 2009). The two weights from the excavation of »Humlegården 3« were discovered in contexts dating to 1010-1030 AD (Hum 3:101550/1550 [Wikström 2008, 296 f.]) and 1050-1065 AD (Hum 3:103227/3226 [Wikström 2008, 352 f.]). The recreated mass of the latter fits very well into the Baltic Sea system. It is also very well preserved and a nice example of the biconical shape common for this period (fig. 3).

As the study failed to identify Sperber's 3.19 g unit in this material, a match of his results was made against the Baltic Sea system (tab. 2). Two of Sperber's weights show an unacceptable deviation against the Baltic Sea system, compared to none against the 3.19 g unit. However, it is then necessary to consider that the 3.19 g unit is in fact proposed solely on statistical grounds, being the best mathematical fit for this particular population, so this is to be expected. Apart from that, as discussed above, there are no other evidence for its existence. It is the interpretation of the author, based upon the statistical analysis in conjunction with the archaeological evidence, that the Baltic Sea system was retained in Sigtuna even though the trade in Islamic silver had effectively ended.

The reasons for holding on to the system might lie in certain fundamental differences in the economic pre-conditions of the late 9<sup>th</sup> century (the adoption of the Baltic Sea system) compared to the late 10<sup>th</sup> century (the founding of Sigtuna). Primarily, the switch to the Baltic Sea system was not so much a result of trade with the Caliphate as it was with the Volga Bulgars. For even though the Volga Bulgars had their own minting at this time, at least the trade with Scandinavia was weight-based. In trading with Western Europe compatibility between weight systems would have been less important as the economy there was monetary-based. Other regions around the Baltic, still in the late 10<sup>th</sup> century employing a weight economy, had for the last century been using the Baltic Sea system. So there would have been no practical purpose to change this, even though the initial reasons for its implementation were gone. On the contrary, through a century of use the Baltic Sea system would have become generally accepted. In addition, the mix of Germanic coins from Scandinavian sites is more reminiscent of depots found in the Western Slavonic region, at this time including the Baltic coast of today's Germany (Schultzén 2005, 22; see Kilger 2000, 321 f.). It might be that the Germanic coins discovered in Sigtuna, to a greater extent, were the result of transit trade through this region, rather than direct trade with the *emporìa* (cf. Hodges 2000) of the Holy Roman Empire. This is also supported by the archaeological finds in Sigtuna which points to a sizeable material and cultural exchange with the Western Slavonic region (see Roslund 2001, 205 ff.).

## References

- Brather 2010: S. Brather, Silver, weights and scales around the Baltic, 8<sup>th</sup> to 11<sup>th</sup> centuries. In: B. Ludowici / H. Jöns / S. Kleingärtner / J. Scheschkewitz / M. Hardt (eds), Trade and Communication Networks of the First Millennium AD in the Northern Part of Central Europe. Central Places, Beach Markets, Landing Places and Trading Centres. Neue Studien zur Sachsenforschung 1 (Stuttgart 2010) 143-164.
- Dolley / Metcalf 1961: R. Dolley / D. Metcalf, The reform of the English coinage under Eadgar. In: Anglo-Saxon Coins [Festschrift F. M. Stenton] (London 1961) 138-168.
- Fernstål 2008: L. Fernstål, A Bit Arabic – Pseudo-Arabic inscriptions on Viking Age weights in Sweden and expressions of self-image. Current Swedish Archaeology 15-16, 2008, 61-71.
- Frye 2006: R. N. Frye, Ibn Fadlan's Journey to Russia: A Tenth-Century Traveler from Baghdad to the Volga River (Princeton 2006).
- Gustin 1997: I. Gustin, Islam, merchants or king? Who was behind the manufacture of Viking Age weights? In: H. Andersson / P. Carelli / L. Ersgård (eds), Visions of the past – trends and traditions in Swedish medieval archaeology. Lund Studies in Medieval Archaeology 19 (Stockholm 1997) 163-177.
- 2004: I. Gustin, Mellan gåva och marknad: handel tillit och materiell kultur under vikingatid. Lund Studies in Medieval Archaeology 34 (Stockholm 2004).
- Hinz 1970: W. Hinz, Islamische Masse und Gewichte: umgerechnet ins metrische System. In: E. J. Brill (ed.), Handbuch der Orientalistik.



- Abteilung 1: Der Nahe und Mittlere Osten, Ergänzungsband 1, 1 (Leiden, Köln 1970).
- Hodges 2000: R. Hodges, *Towns and Trade in the Age of Charlemagne* (London 2000).
- Holm 1987: S. Holm, *Statistical methods for module problems*. Tor 21 (Gothenburg 1987).
- Hårdh 2007: B. Hårdh, *Oriental-Scandinavian contacts on the Volga, as manifested by silver rings and weight systems*. In: J. Graham-Campbell / G. Williams (eds), *Silver economy in the Viking Age* (Walnut Creek 2007) 135-147.
- Kilger 2000: C. Kilger, *Pfennigmärkte und Währungslandschaften. Monetarisierungen im sächsisch-slavisches Grenzland ca. 965-1120*. *Commentationes de nummis saeculorum IX-XI in Suecia repertis*; Nova series 15 (Stockholm 2000).
- 2007: C. Kilger, *Kaupang from Afar. Aspects of the interpretation of Dirham finds in northern and eastern Europe between the late 8th and early 10th centuries*. In: D. Skre (ed.), *Means of exchange. Dealing with silver in the Viking Age. Kaupang excavation project publication series 2* (Aarhus 2007) 199-252.
- Kyhlberg 1980: O. Kyhlberg, *Vikt och värde. Arkeologiska studier i värdemätning, betalningsmedel och metrologi under yngre järnålder. I Helgö. II Birka*. *Stockholm Studies in Archaeology 1* (Stockholm 1980).
- Landgren 1999: J. Landgren, *Birka och det islamiska silvret. Ett tolkningsförslag, baserat på det vikingatida numismatiska materialet i Sverige och Ryssland, till orsakerna bakom Birkas upphörande* (Stockholm 1999).
- Lapidus 2002: I. M. Lapidus, *A history of Islamic societies* (Cambridge 2002).
- Noonan 1986: T. S. Noonan, *Early 'Abbasid mint output*. *Journal of the Economic and Social History of the Orient* 29, 1986, 113-175.
- 1990: T. S. Noonan, *Dirham exports to the Baltic in the Viking Age: some preliminary observations*. In: *Sigtuna Papers. Proceedings of the Sigtuna Symposium on Viking-Age Coinage, 1-4 June 1989*. *Commentationes de nummis saeculorum IX-XI in Suecia repertis*; Nova series 6 (Stockholm 1990) 251-258.
- 2000-2001: T. S. Noonan, *Volga Bulgharia's Tenth-Century Trade with Samanid Central Asia*. *Archivum Eurasiae Medii Aevi* 11, 2000-2001 (2001), 140-218.
- Östergren 1989: M. Östergren, *Mellan stengrund och stenhus. Gotlands vikingatida silverskatter som boplatzindikation*. *Theses and papers in archaeology 2* (Stockholm 1989).
- Pritsak 1998: O. Pritsak, *The Origins of the Old Rus' Weights and Monetary Systems. Two Studies in Western Eurasian Metrology and Numismatics in the Seventh to Eleventh Centuries* (Cambridge, Mass. 1998).
- Rispling 1990: G. Rispling, *The Volga Bulgarian Imitative Coinage of Al-Amir Yaltawar (»Barman«) and Mikail B. Jafar*. In: *Sigtuna Papers. Proceedings of the Sigtuna Symposium on Viking-Age Coinage, 1-4 June 1989*. *Commentationes de nummis saeculorum IX-XI in Suecia repertis*; Nova series 6 (Stockholm 1990) 275-282.
- 2004: G. Rispling, *Catalogue and Comments on the Islamic Coins from the Excavations 1990-1995*. In: B. Ambrosiani (ed.), *Excavations in the Black Earth 1990-1995. Eastern Connections 2: Numismatics and Metrology*. *Birka Studies 6* (Stockholm 2004) 26-60.
- Roslund 2001: M. Roslund, *Gäster i huset. Kulturell överföring mellan slaver och skandinaver 900 till 1300*. *Skrifter Utgivna av Vetenskapssocieteten i Lund* 92 (Lund 2001).
- Schultzén 2004: J. M. Schultzén, *Vid jordens yttersta gräns. En granskning av framlagda teorier kring Birka & Sigtuna* (Stockholm 2004).
- 2005: J. M. Schultzén, *I Europas utmark. Sigtunas handelsvägar och kulturkontakter i äldsta medeltid* (Stockholm 2005).
- 2009: J. M. Schultzén, *Devaluing the mitqal. Inherent Trading Fees in the Metrics of Birka* (Stockholm 2009).
- 2011: J. M. Schultzén, *Remodelling the past. Archaeometrological analysis applied on Birka weight material using a 3D scanner & computer-aided design*. *Journal of Archaeological Science* 38, 2011, 2378-2386.
- Söderberg 1996: A. Söderberg, *Schmelzkugeln. Identifikation av en hantverksprocess. Fyndmaterial från Birka och Sigtuna*. In: *C/D-uppsatser i laborativ arkeologi läsåret 95/96*, 2 (Stockholm 1996).
- 2008: A. Söderberg, *Metall- och glashantverk*. In: *Wikström 2008*, 97-130.
- Sperber 1996: E. Sperber, *Balances, Weights and Weighing in Ancient and Early Medieval Sweden. Theses and Papers in Scientific Archaeology 2* (Stockholm 1996).
- 2004: E. Sperber, *Metrology of the Weights from the Birka Excavations 1990-1995*. In: B. Ambrosiani (ed.), *Excavations in the Black Earth 1990-1995. Eastern Connections 2: Numismatics and Metrology*. *Birka Studies 6* (Stockholm 2004) 61-95.
- Steuer 1973: H. Steuer, *Gewichte aus Haithabu*. In: *Berichte über die Ausgrabungen in Haithabu 6* (Neumünster 1973) 9-22.
- 1987a: H. Steuer, *Der Handel der Wikingerzeit zwischen Nord- und Westeuropa aufgrund archäologischer Zeugnisse*. In: K. Düwel / H. Jankuhn / H. Siems / D. Timpe (eds), *Untersuchungen zu Handel und Verkehr der vor- und frühgeschichtlichen Zeit in Mittel- und Nordeuropa. 4: Der Handel der Karolinger- und Wikingerzeit. Abhandlungen der Akademie der Wissenschaften zu Göttingen, Philologisch-Historische Klasse 3. Folge*, 156 (Göttingen 1987) 113-197.
- 1987b: H. Steuer, *Gewichtsgeldwirtschaften im frühgeschichtlichen Europa*. In: K. Düwel / H. Jankuhn / H. Siems / D. Timpe (eds), *Untersuchungen zu Handel und Verkehr der vor- und frühgeschichtlichen Zeit in Mittel- und Nordeuropa. 4: Der Handel der Karolinger- und Wikingerzeit. Abhandlungen der Akademie der Wissenschaften zu Göttingen, Philologisch-Historische Klasse 3. Folge*, 156 (Göttingen 1987) 405-527.
- 2012: H. Steuer, *Waagen und Gewichte in Janów*. In: S. Brather / M. Jagodziński (eds), *Der wikingerzeitliche Seehandelsplatz von Janów (Truso): geophysikalische, archäopedologische und archäologische Untersuchungen 2004-2008*. *Zeitschrift für Archäologie des Mittelalters Beiheft 24* (Bonn 2012) 185-282.
- Valeev 1995: R. M. Valeev, *Volžskaja Bulgarija. Torgovlja i denezno-vesovye sistemy IX-načala XIII vekov* (Kazan' 1995).
- Vikan / Nesbitt 1980: G. Vikan / J. Nesbitt, *Security in Byzantium: locking, sealing and weighing*. *Dumbarton Oaks Byzantine Collection Publications 2* (Washington, D. C. 1980).
- Wikström 2008: A. Wikström, *På väg mot paradiset: arkeologisk undersökning i kvarteret Humlegården 3 i Sigtuna 2006. Meddelanden och rapporter från Sigtuna museum 33* (Sigtuna 2008).

**Zur Metrologie von Birka und dem frühen Sigtuna –  
Instrumente des Handels im Gebiet des Mälarensees (Schweden) zur Wikingerzeit**

Dieser Aufsatz befasst sich mit den Gewichten von der Fundstelle Birka, dem wichtigsten Handelszentrum im Gebiet des Mälarensees und -tals zur Wikingerzeit, sowie von ihrem Nachfolger, der mittelalterlichen Stadt Sigtuna. Es wird untersucht, welches Gewichtssystem für den Handel in dieser Region und in dieser Epoche verwendet wurde. Es zeigt sich, dass die Gewichte eine lokale Variante (das Ostsee-System) des zeitgleichen Gewichtssystems des Kalifats darstellen. Weiter behandelt dieser Beitrag die Gründe für die Verwendung dieser Gewichtseinheiten und warum sie noch in Sigtuna gebraucht wurden, nachdem der Handel sich schon in Regionen verlagert hatte, wo andere Gewichte vorgeschrieben waren. Wir schlagen vor, dass der im späten 10. Jahrhundert angestiegene Handel mit Westeuropa hauptsächlich über die westslawischen Gebiete abgewickelt wurde, die zu diesem Zeitpunkt immer noch das Ostsee-Gewichtssystem verwendeten. Außerdem gab der direkte Handel mit den auf Münzwirtschaft basierenden Regionen, wie mit dem Heiligen Römischen Reich und mit England, wenige Anreize für einen Wechsel.

**On the metrology of Birka and early Sigtuna –  
tools of trade in the Viking Age Lake Mälaren Valley (Sweden)**

This paper analyses weights from the site of Birka, the main centre for trade in the Lake Mälaren Valley during the Viking Age, as well as its successor, the medieval town of Sigtuna, with the purpose of identifying which weight system was employed for trade in the area and period. The results show that the system was a local variant (the Baltic Sea system) of the contemporary weight system of the Caliphate. Further, the paper deals with the reasons for implementing this system and why it remained in use in Sigtuna even after trade had shifted to areas where other weight systems were decreed. We propose that the increased trade with Western Europe in the late 10<sup>th</sup> century to a large extent was conducted via the Western Slavonic region, which would, at this time, still have employed the Baltic Sea system, and further that direct trade with monetary economies such as the Holy Roman Empire and England would have given little incentive for change.

**À propos de la métrologie de Birka et du début de Sigtuna –  
outils d'échanges dans la vallée du lac Mälaren (Suède) à la période Viking**

Cet article traite de poids découverts dans le site de Birka, le site d'échanges le plus important de la vallée du lac Mälaren à la période Viking et de son successeur dans le temps, la ville médiévale de Sigtuna. Les poids ont été analysés dans le but d'identifier le système pondéral utilisé dans la région à cette époque. Les résultats indiquent que le système de poids était une variante locale (le système de la mer Baltique) du système contemporain du califat. L'article traite également des raisons pour lesquelles le système a été implémenté et maintenu à Sigtuna alors que le commerce s'était déplacé dans d'autres zones utilisant d'autres systèmes pondéraux. La théorie proposée est que l'augmentation du commerce avec l'Ouest européen à la fin du 10<sup>e</sup> siècle s'est opérée via les régions slaves occidentales, qui employaient toujours à l'époque le système de la mer Baltique et que le commerce direct avec par exemple le Saint-Empire romain germanique et l'Angleterre n'aurait eu un attrait que limité pour le change, dans la mesure où il s'agit d'économies monétaires.

Traduction: L. Bernard

*Schlüsselwörter / Keywords / Mots clés*

Schweden / Wikingerzeit / Handel / Metrologie / Gewichtssystem / Dirhem  
Sweden / Viking Age / trade / metrology / weight system / dirham  
Suède / période Viking / commerce / métrologie / système de poids / dirham

**Joakim M. Schultzen**

Stockholms Universitet  
Institutionen för arkeologi och antikens kultur  
Arkeologiska forskningslaboratoriet  
Wallenberglaboratoriet  
S - 106 91 Stockholm  
joakim.schultzen@arklab.su.se

## BESTELLUNG DES ARCHÄOLOGISCHEN KORRESPONDENZBLATTS

Das Archäologische Korrespondenzblatt versteht sich als eine aktuelle wissenschaftliche Zeitschrift zu Themen der vor- und frühgeschichtlichen sowie provincialrömischen Archäologie und ihrer Nachbarwissenschaften in Europa. Neben der aktuellen Forschungsdiskussion finden Neufunde und kurze Analysen von überregionalem Interesse hier ihren Platz. Der Umfang der Artikel beträgt bis zu 20 Druckseiten; fremdsprachige Beiträge werden ebenfalls angenommen. Unabhängige Redaktoren begutachten die eingereichten Artikel.

Kontakt für Autoren: **korrespondenzblatt@rgzm.de**

Abonnement beginnend mit dem laufenden Jahrgang; der Lieferumfang umfasst 4 Hefte pro Jahr; ältere Jahrgänge auf Anfrage; Kündigungen zum Ende eines Jahrganges.

Kontakt in Abonnement- und Bestellangelegenheiten: **verlag@rgzm.de**

Preis je Jahrgang (4 Hefte) für Direktbezieher 20,- € (16,- € bis 2007 soweit vorhanden) + Versandkosten (z. Z. Inland 5,50 €, Ausland 16,- €).

### HIERMIT ABONNIERE ICH DAS ARCHÄOLOGISCHE KORRESPONDENZBLATT

Name \_\_\_\_\_

Straße \_\_\_\_\_

Postleitzahl/Ort \_\_\_\_\_

Sollte sich meine Adresse ändern, erlaube ich der Deutschen Post, meine neue Adresse mitzuteilen.

Datum \_\_\_\_\_ Unterschrift \_\_\_\_\_

Ich wünsche folgende Zahlungsweise (bitte ankreuzen):

bequem und bargeldlos durch **SEPA-Lastschriftmandat** (innerhalb des Euro-Währungsraumes)

Gläubiger-Identifikationsnummer: (DE19ZZZ00000089352) Mandatsreferenz: (Kunden-Nr.) \_\_\_\_\_

Ich ermächtige hiermit das Römisch-Germanische Zentralmuseum, Zahlungen für offenstehende Forderungen von meinem Konto mittels SEPA-Lastschrift einzuziehen. Zugleich weise ich mein Kreditinstitut an, die vom Römisch-Germanischen Zentralmuseum auf mein Konto gezogenen Lastschriften einzulösen.

Hinweis: Ich kann innerhalb von acht Wochen, beginnend mit dem Belastungsdatum, die Erstattung des belasteten Betrages verlangen. Es gelten dabei die mit meinem Kreditinstitut vereinbarten Bedingungen.

Name \_\_\_\_\_

Straße \_\_\_\_\_

Postleitzahl/Ort \_\_\_\_\_

IBAN 

--	--	--	--	--	--	--	--	--	--	--	--	--	--	--	--	--	--

Bankname \_\_\_\_\_

BIC 

--	--	--	--	--	--	--	--	--	--	--	--	--	--

Ort, Datum \_\_\_\_\_ Unterschrift \_\_\_\_\_

durch sofortige **Überweisung** nach Erhalt der Rechnung (Deutschland und andere Länder)

Ausland: Nettopreis 20,- €, Versandkosten 12,70 €, Bankgebühren 7,70 €

Bei Verwendung von Euro-Standardüberweisungen mit IBAN- und BIC-Nummer entfallen unsere Bankgebühren (IBAN: DE 08 5519 0000 0020 9860 14; BIC: MVBM DE 55), ebenso, wenn Sie von Ihrem Postgirokonto überweisen oder durch internationale Postanweisung zahlen.

Das Römisch-Germanische Zentralmuseum ist nicht umsatzsteuerpflichtig und berechnet daher keine Mehrwertsteuer.

Senden Sie diese Abo-Bestellung bitte per Fax an: 0049 (0) 61 31 / 91 24-199, per E-Mail an **verlag@rgzm.de** oder per Post an