



MAHMOUD S. BASHIR & ROMAIN DAVID

MEROITIC POTTERY FROM EXCAVATIONS OF THE CEMETERY AT BERBER

INTRODUCTION

The recent discovery of a possible large and well preserved Meroitic cemetery at Berber (between the 5th and 6th cataract) is of considerable interest and constitute a great research potential in the Meroitic funerary traditions (Mahmoud Bashir, 2010). The excavated tombs from this cemetery provided quite a large number of objects, with a great diversity in both the types of material and the quantity found in each tomb. In fact, findings of large amount and well preserved pottery constitute an important feature for the Meroitic cemetery at Berber. The cemetery has been so far the object of rescue operations carried out by the National Corporation for Antiquities and Museums (NCAM) with a logistic support from the *Section Française de La Direction des Antiquités du Soudan* (SFDAS) (Bashir 2010). In addition, since the ceramic material from previous excavations was stored in Khartoum, it was possible for the SFDAS to conduct extensive studies of the material¹ as part of this ongoing cooperation.

CERAMICS FABRIC AND FORM

As the potsherds unearthed during field work were left on the site, the study focused on 75 complete bowls and jars from the 15 excavated tombs. Paradoxically, the quality of this intact material for ceramologists used to deal with broken pieces has disrupted our capacity to distinguish the different types of fabric. But the variety of ceramic shapes as well as the exceptional preservation of the contexts offers a good understanding of Meroitic funerary ceramic in that region. We illustrate here a selected material from four different tombs which, according to us, best represent the Berber necropolis productions. Pots

are shown by context even if they are described by typology.

Partly broken pots serve as bases for description of each fabric type. We had to use the chipped part of rim or scratched area on ceramics to attempt to fit a pot into one or another category. Hand lens with 10x magnification has been used to examine samples. Microscope with 40x magnification helped us to complete the general description. Variation in clay, temper, inclusions and surface treatments were taken into account to establish the fabric typology. A wider study embracing all the sherds found within the site area is needed to obtain a real overview of the site's productions but we are still able to distinguish at least ten groups or sub-groups of fabrics linked with peculiar shapes.

1. Silt ware bowls

The most common fabric type is a rather fine, quite hard and dense silt ware (named fabric B1). When broken, light reddish-brown (7.5YR 6/4) fringes with a fine light grey core (2.5YR N6) or rarely a black core (2.5YR N 2.5) can be seen. Medium to frequent fine straw temper, sparse scratched particles of limestone, some fine to very fine sand, mica and red ferric particles are the main inclusions quoted. Only bowls of various shapes are made in that fabric. They are all red-slipped on both faces and can be burnished (B1a), smoothed (B1b) or polished (B1c). Different productions linked with the Meroe region can be isolated. Simple ledge-rimmed bowls are the most familiar among the funerary ceramic furniture (fabric B1a-B1b). From 10 excavated tombs, 28 bowls of that type have been unearthed. Their rim can be elongated (Fig. 3.1), rather triangular (Fig. 1.3) and even quite rounded (Fig. 6.4). The base appears sometimes flat or with a very low foot just sketched by the finger or a sharp tool. Three of them bear decoration at the top of the rim, one molded (Fig. 4.2),² another

1 The project involved the authors (PhD student with a scholarship from the SFDAS, and PhD student with scholarship from the NCAM in Khartoum University) and Suzan ADIL from the Khartoum University as a training course. She has participated in drawing and describing some of the material published in this contribution.

2 That kind of decoration might come from faience. Dunham 1963: fig. 140d.

incised³ (Fig. 4.1) and the last one is painted (Fig. 6.1). Numerous bowls have cracked bottoms. That characteristic marks appear during the drying phase, when the bowl is made by “throwing off the hump”.⁴ The main production seems to have been restricted to the region of Meroe⁵ but similar bowls are also present in Nubia as far as Kerma, Sai and even Faras.⁶ If our samples seem to belong to the same category, variation of base and rim, particularly in Meroe Western Cemetery, yield some chronological feature: Ringed-base bowl (F13) predates deep bowl with a rather wide rim (K16), which in turn can be placed before bowls of our types (E26).⁷ The former version of that bowl may be seen as an imitation of a Roman shape from the first century A.D. Similar shaped bowls have been unearthed in Natakamani’s palace at Gebel Barkal⁸ and in Amanitenmomide’s tomb at Meroe.⁹ This tends to indicate the second half of the first century-beginning of the second century A.D. as a starting point. Others were discovered in the Teqorideamani’s tomb as well as in W109.¹⁰ Both of them are dated around the mid-third century A.D.¹¹

Other ledge-rimmed bowls have a rounded base (Fig. 4.3, 6.3). They appear in two graves with their flattened bottom counterpart. They can be ascribed to an identical date range.¹²

Plain red slipped bowls, well finished, complete the collection of Fabric B1 (Fig. 6.2). They are fairly common and are distributed in the entire Meroitic kingdom from the second century A.D. Finer sample (Fig. 3.2) would fit in with an earlier date, during the first century A.D.¹³

2. Fine ware bowls

Fine ware samples are well represented among the Berber material. Two different groups have been

distinguished. The first one is made from kaolinitic or white clay, smooth, quite hard and dense. The color range is from white (10 YR 8/2) to pinkish white (5 YR 8/2). Sparse to medium inclusions of fine sand, some fine mica, limestone (0.5 to 1.5 mm), small red ferric particles (0.2 to 0.5 mm.) have been noticed. According to the different types of surface treatment, we separated this fabric into two sub-categories. Painted and sometimes stamped wheel-made bowls enter in B3a (Fig. 1.2, 3.4, 4.4-5). Wheel-made bowls only red slipped outside (2.5 YR 6/8) and painted inside are in B3b (Fig. 1.1). Parallels can be established with Nubia¹⁴ even the main distribution seems to be limited to Meroe region.¹⁵ Their presence in Nubia might bring to light trade activities from the South to the North. The grey-pinkish color filling the motives of two bowls (Fig. 1.1, 4.5) has been dated from the mid-first century to mid-second century A.D. by L. Török.¹⁶ Other parallels can be found but do not provide a more accurate chronology of such production. Another fine ware fabric (B4) is rather similar in color and composition to fabric B3. We just have noticed small black ferric particles that seem to be absent from the former. Ledge-rimmed bowls (Fig. 1.4) that are considered as finer version of the silt ware common bowls are the only specimen detected. They also appear in Mussawarat and Gabati.¹⁷

3. Silt ware Jars

Jars made in silt ware (B6) are quite common (Fig. 2.2-3, 5.4). The break shows mainly light red (2.5YR 6/8) outer fringes and a dark grey core (2.5YR N4). Some variability in the color has been quoted. Fringes can be redder with a black core. Frequent fine to coarse straw temper, fine limestone inclusions in medium frequency, little fine to very fine white, black, red particles and mica have also been quoted. Most of jars are coated with light red-orange slip. That type of container is usually found in graves as well as in domestic context.¹⁸ Parallels from the Meroe cemeteries can be used to insert them in a chronological sequence. Jar type L3 (Fig. 2.3, 5.4) has been buried within the tomb of King

3 Dittrich 2003: Abb. 6.2

4 Robertson & Hill 2004: 111-115.

5 Shinnie & Bradley 1980: P40 to P44; Grzysky 2003: fig. 23, 32; Dunham 1963: fig. C16, C18, E26, F11-14, K16-19; Edwards 1999a: 24, pl. VIII; Edwards 1998: 144, 168, fig. 6.12, 6.13.

6 David 2010: 60, fig. 1a; Reisner 1923: fig. 14; Faras unpublished material SNM 14707, from Meroitic Houses: Adams 2005: 42-46.

7 Edwards 1999b: fig. 6.

8 Vincentelli 1994: fig. 6, with a ringed base.

9 Dunham 1957: 143, fig. 94, with a flat base, dated from the beginning of the 2nd c. A.D. Cf. Rilly 2010: 287.

10 Dunham 1957: 186, fig. 122, 21-3-150; Dunham 1963: 199, 22-1-543.

11 The reign of Teqorideamani as well as the stela of Amanikhedololi (REM 0838 found in the roof of W109) were reappraised in Rilly 2001: 79-80.

12 See also Edwards 1998: 26.

13 Edwards 1999b: fig. 6, cf. E4 and E8.

14 Griffith 1924: 162, pl. LI.5-9; Randall-MacIver & Wooley 1910: pl. 93, 8731-8733; Almagro 1965: 73, fig. 58.3.

15 Edwards 1998: 146, fig. 6.12 n° 899/1, 6.16 n° 917/2; (in different fabric), fig. 6.17 n° 12305; Grzysky 2003: 65, fig. 24, n° P60 (see also P 57-59); Edwards 1999a: 31-32, pl. XI; Vercoutter 1962: fig. 28-29.

16 Török 1997: 287-288.

17 Edwards 1998: Fig. 6.16 n° 9413; Edwards 1999: Pl. XIII, n° 821.

18 Edwards 1998: Fig. 6.10 n° 9401, 6.18 n° 9404; Shinnie & Bradley 1980: Fig. 39 n° 114.



Amanitenmomide (Beg. N17)¹⁹ and in many tombs of the Western cemetery (W 17, W 18, W 24, W 102, W 106, W 110, W 166, W 453). The seriation run carried out by D.N. Edwards²⁰ places W 110 as the latest tomb to receive such jar. This grave would be dated about the first half of the third century A.D. by a bronze lamp also unearthed in Takideamani's tomb Beg. N. 29.²¹ Consequently, that production should have been distributed during all the second century A.D. and the first decades of the third century A.D. One jar (Fig. 5.4, 7) displays mark on the shoulder. It has been roughly traced by the potter's finger when the pot was still wet and just covered by a red slip. After firing, the prints remain the only unslipped area of the pot. Such marks might be cautiously compared to engraved motifs on stone in Beg N. 17. Most of the peculiar signs applied to ceramic are realized after the firing and would express the property of elite and a religious symbol within a funerary context. We can interpret our sign as an original mark of craftsman, maybe from a royal production center.²²

As we could not find fresh breaks on each pot, three jars (Fig. 3.5, 5.1-2) classified beforehand as fabric B6 are liable to enter other categories. They seem to have been manufactured by coiling on a slow wheel and their shape is close to hand-made samples. Parallels are quoted in Gabati²³ where C¹⁴ dates gives a broad range around the second century A.D.

4. Hand-made bottles and jars

Hand-made production appears in some tombs of the Berber necropolis. Two fabrics have been isolated but sherds are missing to precise our observation. The first fabric (B7) is a silt ware hackly, quite hard and medium to dense. We can observe light brown (10YR 6/3-4) outer fringes and dark grey to black core (7.5YR N3 or N2.5) in the fracture. Fine to coarse straw temper in medium quantity, some rather coarse limestone, fine sand and mica are the main inclusions. Two bottles correspond to that type. The first form (Fig. 2.1) is a direct descendant of an early Meroitic shape. Its neck is rather short but the general shape corresponds to exemplar from the first to mid-second century A.D.²⁴ The second bottle (Fig. 6.5) is encountered in Meroe, El Kadada and

Gabati cemeteries.²⁵ Its main phase of use took place in the last century of the Meroitic period. However, the former distribution is not known. The similar sample from Gabati could be dated towards the third A.D. and the parallel from El Kadada is identified as typical from the fourth century A.D.

The last fabric (B8) is typical from the region south of Meroe. It is found in large quantity in Muweis and Wad Ban Naga²⁶ and is attested as far as Qasr Ibrim.²⁷ The color of the break is grey (5YR5/1-6/1) on the fringes with a wide brownish-red (5YR 4/6) core. A lot of angular small to coarse quartz and white mineral inclusions are the main characteristics. Some micas and ash (?) are also visible. One jar with inward-sloping short neck and globular body (Fig. 5.3) is the only sample quoted so far. It bears short lines and crosses incised before the firing. They can be paralleled with Western and Northern cemeteries of Meroe.²⁸ Most of them are dated from the third century A.D. but we can expect the beginning of the production some decades earlier.

THE TOMBS CHRONOLOGY

1. BMC 1 (Fig. 1-2)

The presence of painted fine ware bowls and hand-made jar suggests a range date before the end of the second century A.D. On the other side, ledge-rimmed bowl and prototype of Meroe L03 jar appear at the end of the first-beginning of the second century A.D. Finally, the tomb could fit into an end of the first - mid-second century A.D. range date.

2. BMC 4 (Fig. 3)

We do not possess enough element to precise the chronology of that tomb but, on the previous bases, we can expect that the last burial took place after the end of the first century A.D.²⁹ The red rim stripe on the fine ware bowl might be considered as a criterion to define a late fine ware production, towards the mid-second century A.D. A second century A.D. date seems to be secure.

19 Dunham 1957: 144, 21-3-381.

20 Edwards 1999b: fig. 4.

21 Dunham 1963: 225, 22-1-569 to be compared to Dunham 1957: 166, 21-3-160.

22 Török 1972: 42-44.

23 Edwards 1998: 142, 247 (date), fig. 6.1 n° 1801, fig. 6.9 n° 5502.

24 Dunham 1963: 348, fig. L09.

25 Dunham 1963: 346, J12; Lenoble 1987: 93, pl. XII, KDD 119/4/67; Edwards 1998: 26, fig. 2.9 n° 4106, with the same vertical burnishing.

26 Marie Evina: personal communication; Vercoutter 1962: pl. XXc. in the Khartoum National Museum: SNM 62-10-141 to 62-10-158.

27 Rose 1996: 121, 128-129, ware A4.

28 Dunham 1963: fig. J 11, J 13, L 11 (shape and sign); L9, L12-13 (sign); Dunham 1957: 166, fig. 111.

29 This tomb shows evidences of multiple burials but the material seems to belong to the last deceased.

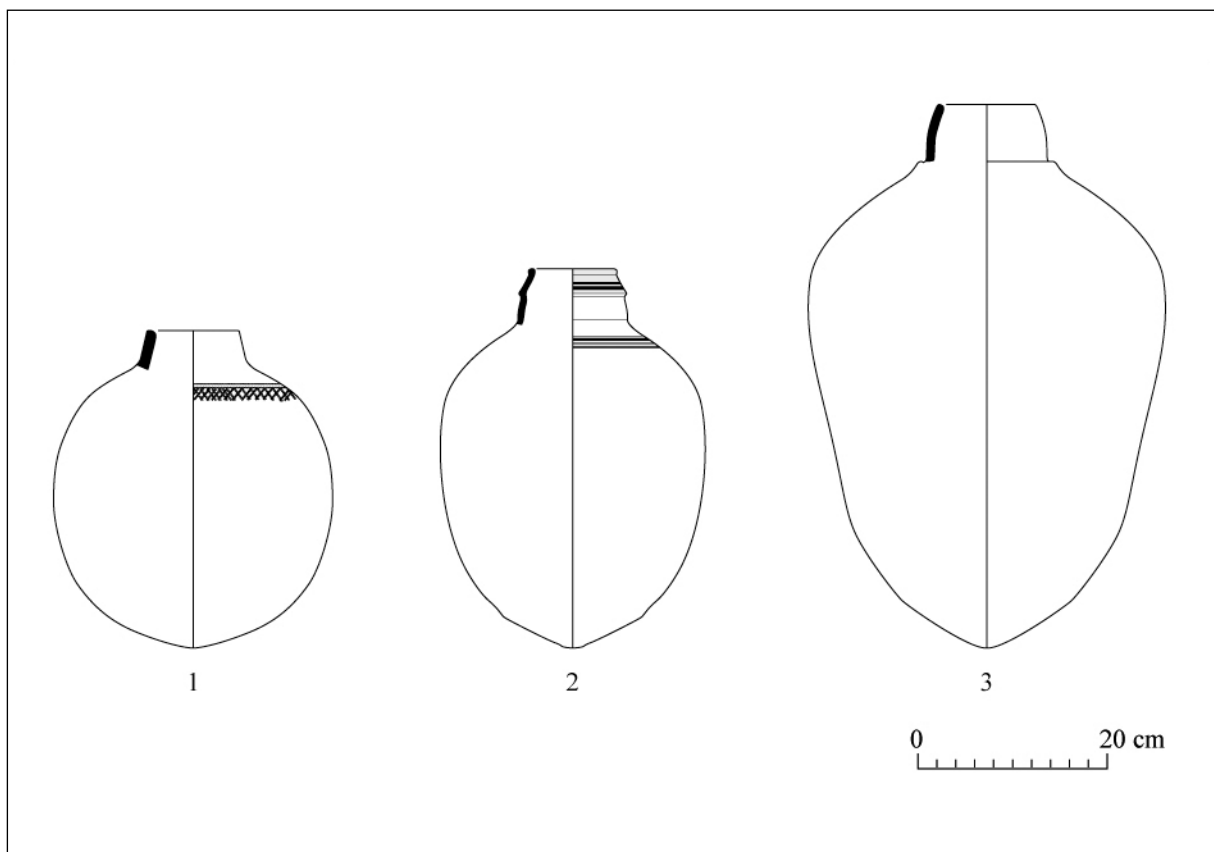
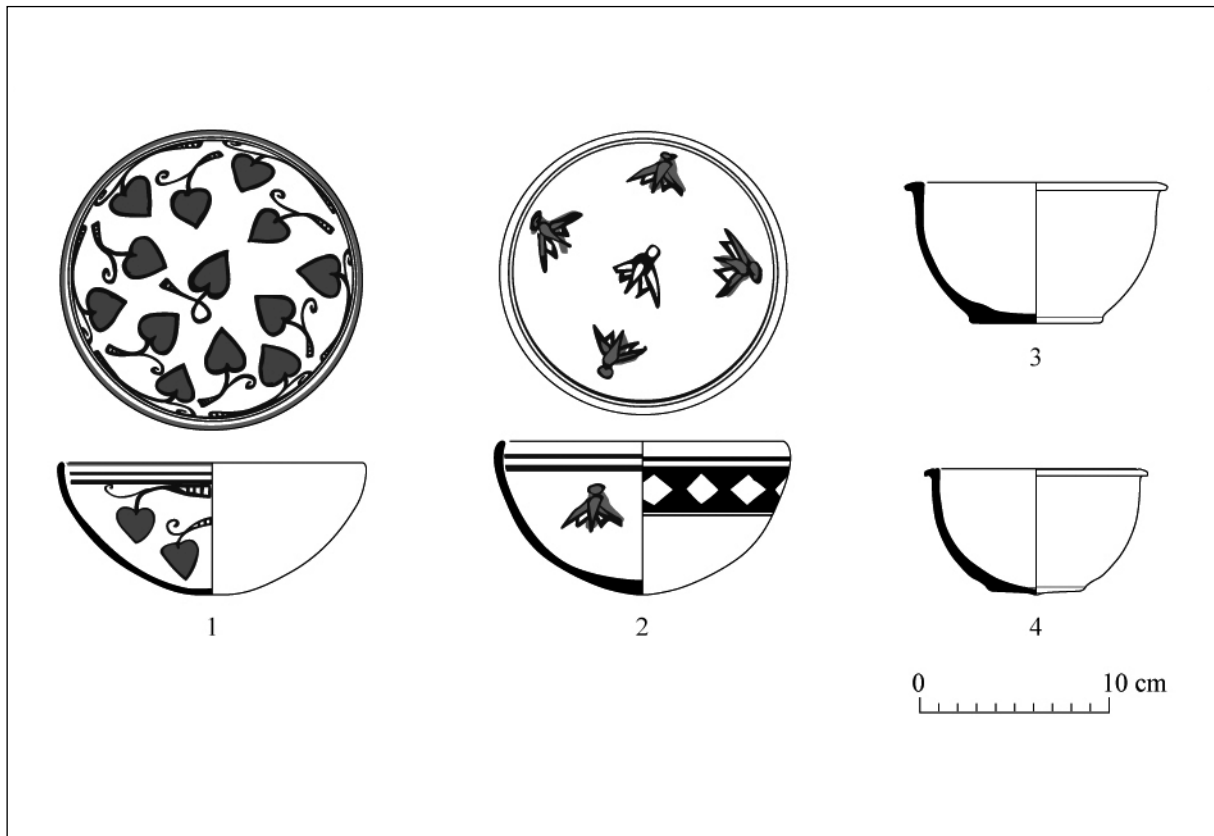

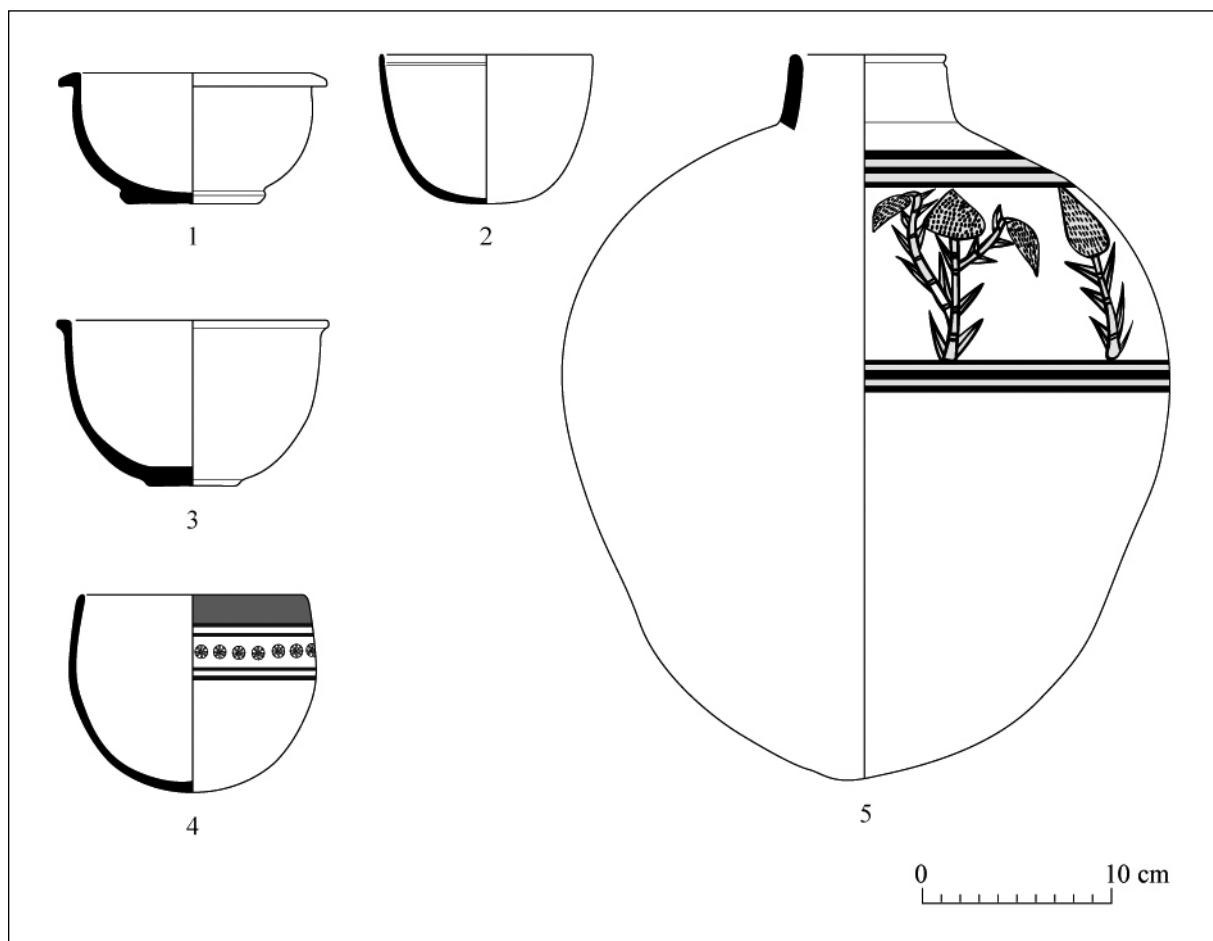

Fig. 3: Selected material from BMC 4 (date: IInd century A.D.).

3. BMC 7 (Fig. 4-5)

Material from BMC 7 seems to be rather late. The hand-made jar is usually attested in third century context except in one case (broken piece in W 453). The same range date should be attributed for the ledge-rimmed bowl with a round bottom, as proposed for the identical shape in BMC 12. The wheel-made jar (fig. 5.4) can be considered as a transitional type between type L03 and K05 from the western cemetery of Meroe. And the fine ware bowls, both bearing a red rim stripe, could be produced before the end of the second century. Hence we can ascribe a mid-second-beginning of the third century A.D. date.

4. BMC 12 (Fig. 6)

Three objects from that tomb find their counterpart in Gabati Tomb 41 dated towards the third century A.D.³⁰ So the same range date can be surely attributed to BMC 12.

CERAMIC IN THE FUNERARY RITUAL

P. Lenoble has greatly contributed to the identification of the role of ceramic within the Meroitic funerary ritual. Many of the aspect he has defined using material from Kadada and Meroe has been noticed in the ceramics from Berber necropolis. The numerous ledge-rimmed bowls found in each graves of the Berber cemetery could be connected to funerary custom consisting in bowls deposit on a basket-tray.³¹ Hand-made bottle, especially the one from BMC 12 (Fig. 6.5) enters within the category of the "petite bouteille noire" which might have played a significant role in the libation.³² Finally, the funerary banquet³³ is revealed by the wheel-made jars in which some organic residues have been noticed.

Among the pottery beer jars, painted jars with floral patterns have been found at Berber cemetery. Motives painted or stamped on the ceramic is referring

31 Lenoble 1991: 247.

32 Lenoble 1995: 143-162.

33 Lenoble 1987: 97-98.

30 Edwards 1998: 25-26, 198, 247.

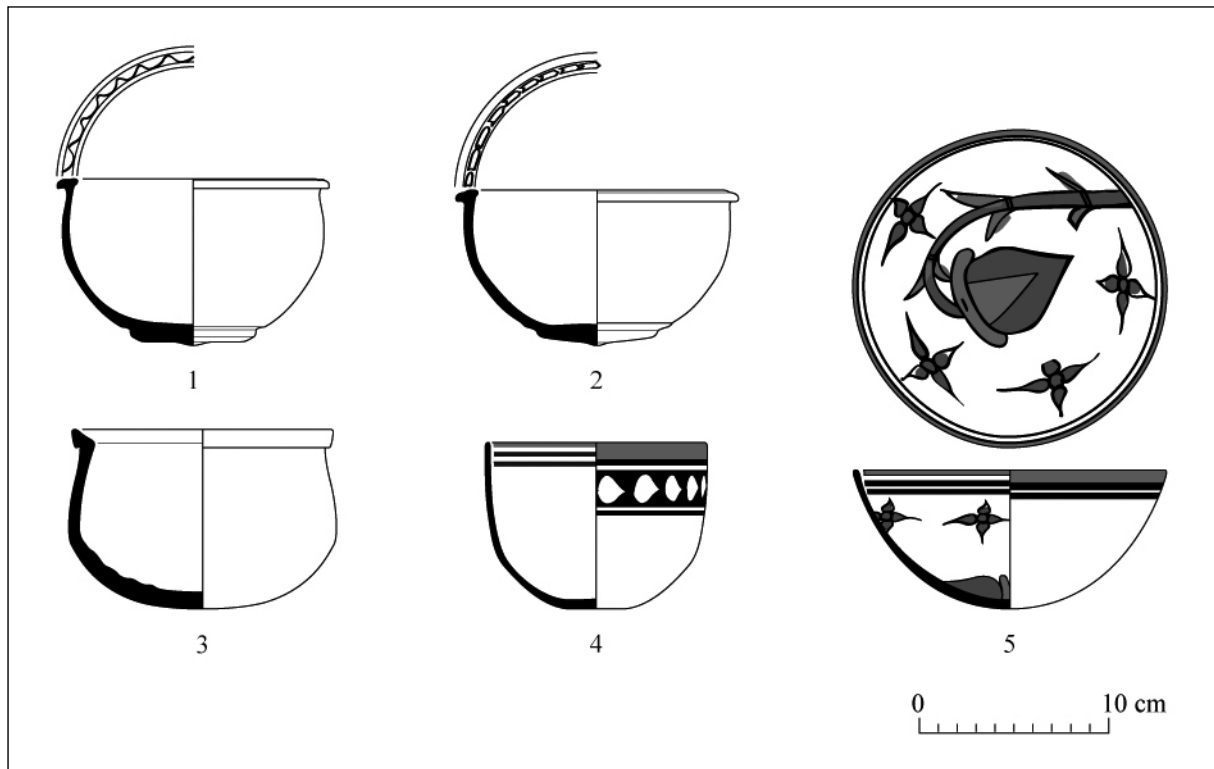

Fig. 4: Selected bowls from BMC 7 (date: mid. IInd-beginning of IIIrd century A.D.).

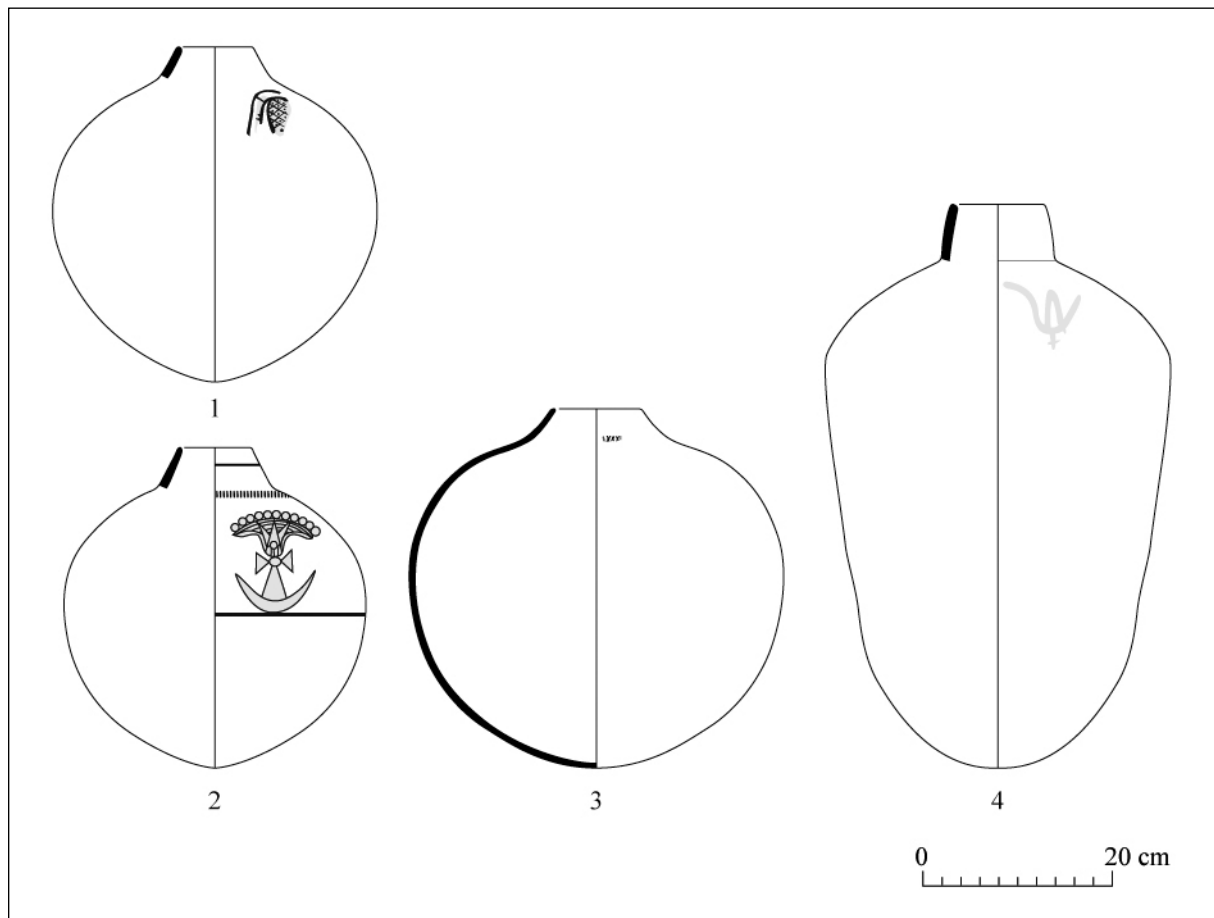

Fig. 5: Selected jar from BMC 7 (date: mid. IInd-beginning of IIIrd century A.D.).

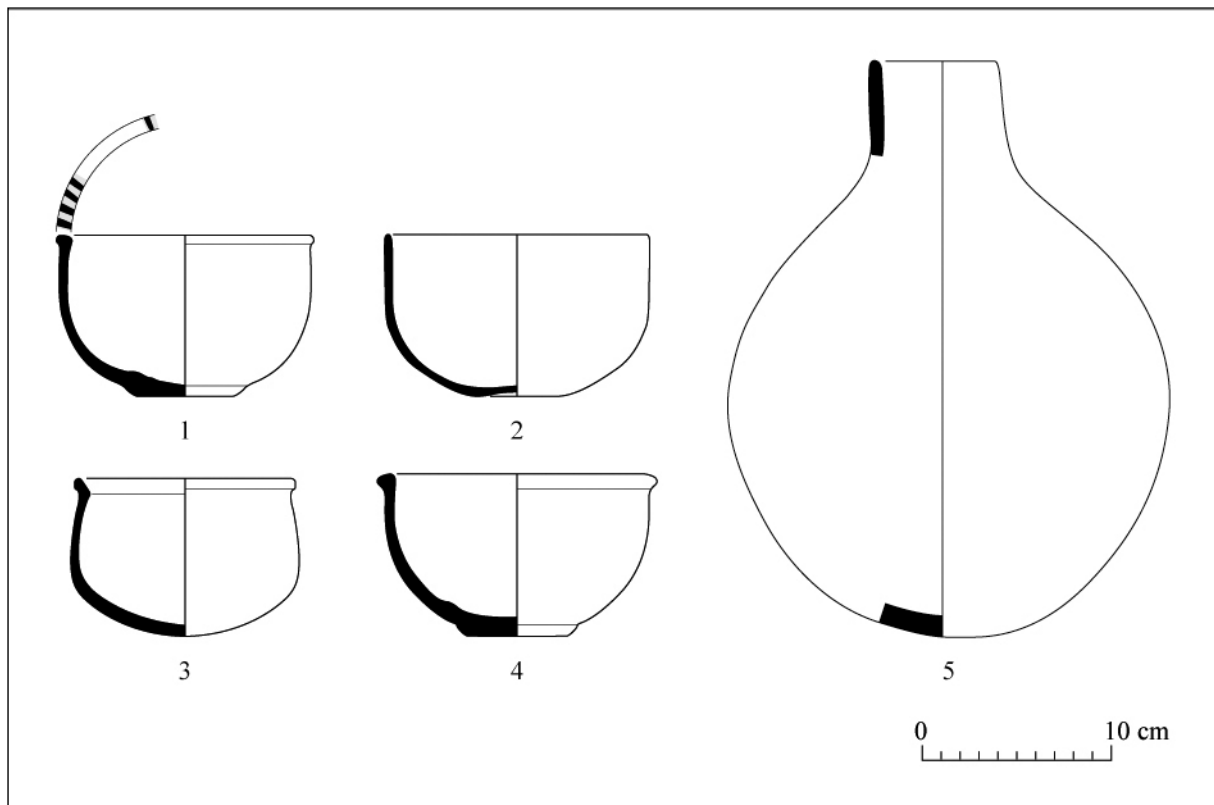

Fig. 6: Complete material from BMC 12 (date: IIIrd century A.D.).

to other belief, linked to religious iconography. However, a number of pottery beer jars and bowls from the cemetery at Berber have shown clear sorghum grains. The depiction of sorghum on a beer jar that have been made on the first place to be used in rituals practices is a clear prove of the importance and the role of sorghum in the local believes and traditions. Moreover, the symbol of the floral patterns especially sorghum on the painted pottery dishes with internal painted decoration demonstrates a symbolic and ritual meaning, since

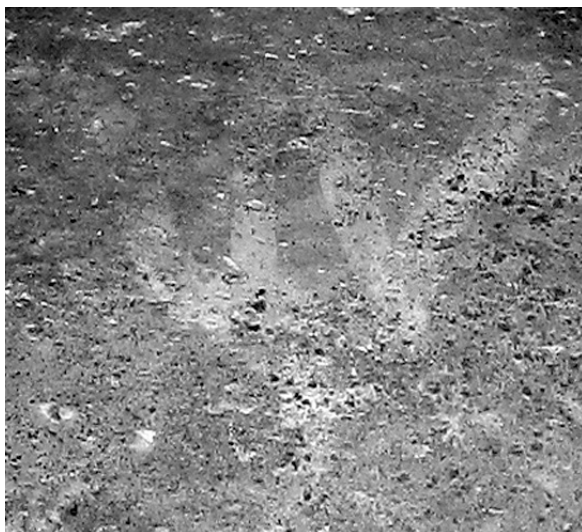

Fig. 7: Potter mark on jar from BMC 7.

such dishes were used for pouring liquids in libation practices. The colored images will then be noticeable when pouring the holy liquids. Generally, the iconographical records of the Meroitic period has showed several examples of sorghum motif, however the most important depiction of sorghum ears has been recorded is King Shorkaror rock carving on a granite boulder at Jebel Qeili east of Khartoum. In fact, at the site of Dangeil, 12km north of Berber, the archaeobotanical analyses on bread moulds from the excavations at the Amun Temple have revealed that sorghum was the grain used for offering, not wheat or barley. (Anderson et al. 2007). In addition, it is important to say that sorghum in the current time is representing the main item in the region food culture.

CONCLUSION

The Berber Meroitic ceramic production points towards Meroe where numerous parallels can be established. The chronology of the cemetery remains still unknown but we can expect a broader date range than the second-third century A.D. As an introductory study, we have shown selected material coming from well preserved contexts to bring to light the importance of that site for the understanding of ceramic production as well as the funerary custom in



the northern part of the Island of Meroe. Thus, urgent and systematic excavations are highly required at the Meroitic cemetery at Berber. In one hand, because the site is facing the risk of the development projects in the surroundings, and on the other hand, we are expecting more valuable information to be revealed from this cemetery.

BIBLIOGRAPHY

- ADAMS, W.Y. (2005): *The West Bank Survey from Faras to Gemai, 2, Sites of Meroitic and Ballaña Age*, Oxford.
- ALMAGRO, A. (1965): *La necropolis meroitica de Nag Gamus (Masmās. Nubia Egipticia)*, Madrid.
- ANDERSON, J., CATHERINE, A., AMANDA, L. & S. MOHAMMED AHMED (2007): Bread Moulds from the Amun Temple at Dangeil, Nile State-An Addendum, *Sudan & Nubia* 11, 89-93.
- BASHIR, M.S. (2010) A Recently Discovered Meroitic Cemetery at Berber, River Nile State, Sudan. Preliminary Report, *Sudan & Nubia* 14, 69-75.
- DAVID, R. (2010): Second report on the ceramics from the Meroitic Cemetery 8-B-5.A, *Sudan & Nubia* 14, 60-61.
- DITTRICH, A. (2003): Meroitische und spätkeroitische Keramik aus Hamadab, in: *Der Antike Sudan, MittSAG* 14, 77-91.
- DUNHAM, D. (1957): *The royal Tombs at Meroë and Barkal. The Royal Cemeteries of Kush IV*, Boston.
- DUNHAM, D. (1963): *The West and South Cemeteries at Meroë, The Royal Cemeteries of Kush V*, Boston.
- EDWARDS, D.N. (1998): *Gabati, A Meroitic, Post-Meroitic and Medieval Cemetery in Central Sudan, Vol. I*, London.
- EDWARDS, D.N. (1999a): *Musawwarat es Sufra III, A Meroitic Pottery Workshop at Musawwarat es Sufra. Meroitica* 17,2.
- EDWARDS, D.N. (1999b): *Meroitic Ceramic Chronology: Exploring the Meroe West Cemeteries, Azania XXXIV*, 25-43.
- GRIFFITH, F.L.L. (1924): *Oxford Excavations in Nubia. The Meroitic Cemetery at Faras*, in: *LAAA* 11, 141-180.
- GRZYMSKY, K. (2003): *Meroe Reports I, SSEA publication XVII*, Mississauga.
- LENOBLE, P. (1987): *Trois tombes de la région de Méroé. La clôture des fouilles historiques d'el Kadada en 1985 et 1986, Archéologie du Nil Moyen* 2, 89-119.
- LENOBLE, P. (1991): *Plateaux de gobelets dans les sépultures méroïtiques, un équipement liturgique de la libation isiaque*, in: W.V. Davies (ed.), *Egypt and Africa, Nubia from Prehistory to Islam*, Londres, 246-252.
- LENOBLE, P. (1995): *La petite bouteille noire, un récipient méroéen de la libation funéraire, Archéologie du Nil Moyen* 7, 143-162.
- RANDALL-MACIVER, D. & C.L. WOOLEY (1910): *Karanog, the Romano-Nubian Cemetery III-IV*, Oxford.
- REISNER, G.A. (1923): *Excavations at Kerma, Part II, Harvard African Studies* 5-6, Cambridge.
- RILLY, C. (2001): *Approche comparative de la paléographie et de la chronologie royale de Méroé, Meroitic Newsletter* 28, 71-84.
- RILLY, C. (2010): *Chronologie des souverains de Méroé*, in: M. Baud et alii (ed.), *Méroé, un empire sur le Nil*, 287.
- ROBERTSON, J.H. & E.M. HILL (2004): *The Meroitic Pottery Industry*, in: P.L. Shinnie, J.R. Anderson (eds.), *The Capital of Kush 2. Meroë Excavations 1973-1984, Meroitica* 20, 109-136.
- ROSE, P. (1996): *Qasr Ibrim. The Hinterland Survey*, London: EES.
- SHINNIE, P.L. & R.J. BRADLEY (1980): *The capital of Kush 1. Meroë Excavations 1965-1972, Meroitica* 4.
- SHINNIE P.L. & J. R. ANDERSON (2004): *The Capital of Kush 2, Meroe Excavations 1973-1984, Meroitica* 20.
- TÖRÖK, L. (1972): *A special group of royal property marks from the 1st to 2nd century A.D., Meroitic Newsletter* 10, 35-51.
- TÖRÖK L. (1997): *Meroe City. An ancient African capital. John Garstang's excavation in the Sudan*, London.
- VERCOUTTER, J. (1962): *Un palais des Candaces contemporain d'Auguste, Syria* 39, 263-299.
- VINCENTELLI, I. (1994): *Administration and Kingship in the Jebel Barkal clay sealing*, in: *Études Nubiennes II, Genève*, 147-156.

ABSTRACT

Berber Meroitic Cemetery provides an important amount of complete ceramics which are very close to Meroe region production. This article constitutes a short presentation of finds from four well preserved burials. Typology, chronology and ceramic function within the Meroitic funerary ritual are tackled by illustrating the main features encountered during the two first seasons of excavations.

ZUSAMMENFASSUNG

Auf dem meroitischen Friedhof von Berber wurden viele komplette Keramikgefäße gefunden, deren Ware und Formen deutlich Richtung Meroe weisen. Hier werden die Gefäße aus vier gut erhaltenen Gräbern der Grabungen der ersten beiden Kampagnen vorgestellt. Typologie, Chronologie und Funktion der Gefäße werden als vorläufige Studie dargestellt.