



CLAUDIA NÄSER &amp; MANJA WETENDORF

## THE MUSAWWARAT POTTERY PROJECT 2014

In the mid 1990s, a substantial ceramic deposit was identified in courtyard 224 of the Great Enclosure at Musawwarat es-Sufra. During the 1997 field season this deposit was explored in a first excavation which produced some 24,200 sherds. The finds were subjected to a preliminary analysis and partly published by David Edwards in 1999. The findings at ‘pottery courtyard’ 224 have now become the focus of a project, which aims to take up the unfinished analyses, continue investigations at the site and shed further light on pottery production and consumption in Musawwarat.<sup>1</sup> One of the first steps in this endeavour was the reconnaissance of the 1997 finds in the storerooms of the Musawwarat dig house in July 2013 and the subsequent archaeometric analysis of 40 samples selected from this material, which were discussed in the previous edition of *Der antike Sudan*.<sup>2</sup> In January 2014 investigations recommenced at the site – first results thereof are presented in this paper.<sup>3</sup>

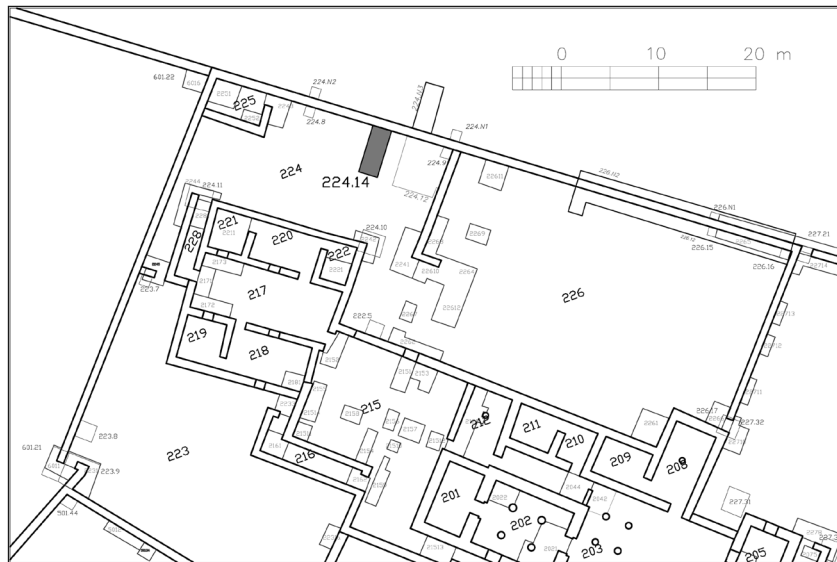

Fig. 1: Excavation plan of courtyard 224 (graphic adaptation: Ralf Miltenberger)

#### ARCHAEOLOGICAL INVESTIGATIONS IN COURTYARD 224

The pottery deposit was detected for the first time in two architectural sondages, 224.8 and 224.9, in the central part of the northern enclosure wall and the northeastern corner of courtyard 224 in the 1995/96 field season (fig. 1).<sup>4</sup> In the 1997 season the deposit was investigated in trench 224.12, enlarging sondage 224.8 to an area of 5 x 5 m.<sup>5</sup>

Trench 224.12 revealed three main stratigraphic components: a topmost layer mainly of wind-blown sand, the ‘pottery deposit’, and a series of strata underneath which testify to an earlier occupation phase of the area.<sup>6</sup> The understanding of the latter was limited due to the circumscribed size of the trench and the inconclusive nature of the findings.

gations continued in Berlin and have been transferred into the PhD project of Manja Wetendorf at the Berlin Graduate School of Ancient Studies, which commenced in October 2014. BerGSAS’ support towards the project is gratefully acknowledged.

1 The project is conducted with funding from the Qatar-Sudan Archaeological Project and the Berlin Cluster of Excellence TOPOI, whose support is gratefully acknowledged. See also <http://www.musawwarat.com/> and <http://www.topoi.org/project/a-6-5/>. The authors would like to express their gratitude to the National Corporation for Antiquities and Museums of Sudan, in particular towards Dr. Abdelrahman Ali and el-Hassan Ahmed Mohammed, for facilitating the export of samples and finds for study in Berlin. The archaeometric analyses of the project are undertaken by Malgorzata Daszkiewicz and Gerwulf Schneider, who are thanked for their fruitful cooperation. We also thank Jens Weschenfelder who helped to prepare several illustrations for this contribution and Gemma Tully who corrected the English.

2 Näser and Daszkiewicz 2013.

3 Excavations lasted from 15th January to 16th February 2014 and were conducted by Claudia Näser, Manja Wetendorf and Stephanie Bruck. Analysis of the find material in Musawwarat lasted until 13th March 2014 and was undertaken by Manja Wetendorf and Stephanie Bruck. Investi-

4 Wenig and Wolf 1998a: 29, map 6, 1998b: 44, 1998c: 29 and Seiler 1998, giving a wrong position (“Südwestecke”) for sondage 224.9. Cf. Edwards 1999: 67, fig. 4.

5 Wenig and Wolf 1998c: 29–33; Edwards 1998, 1999.

6 Edwards and Onasch in Edwards 1999: 8–11, figs. 6–11.

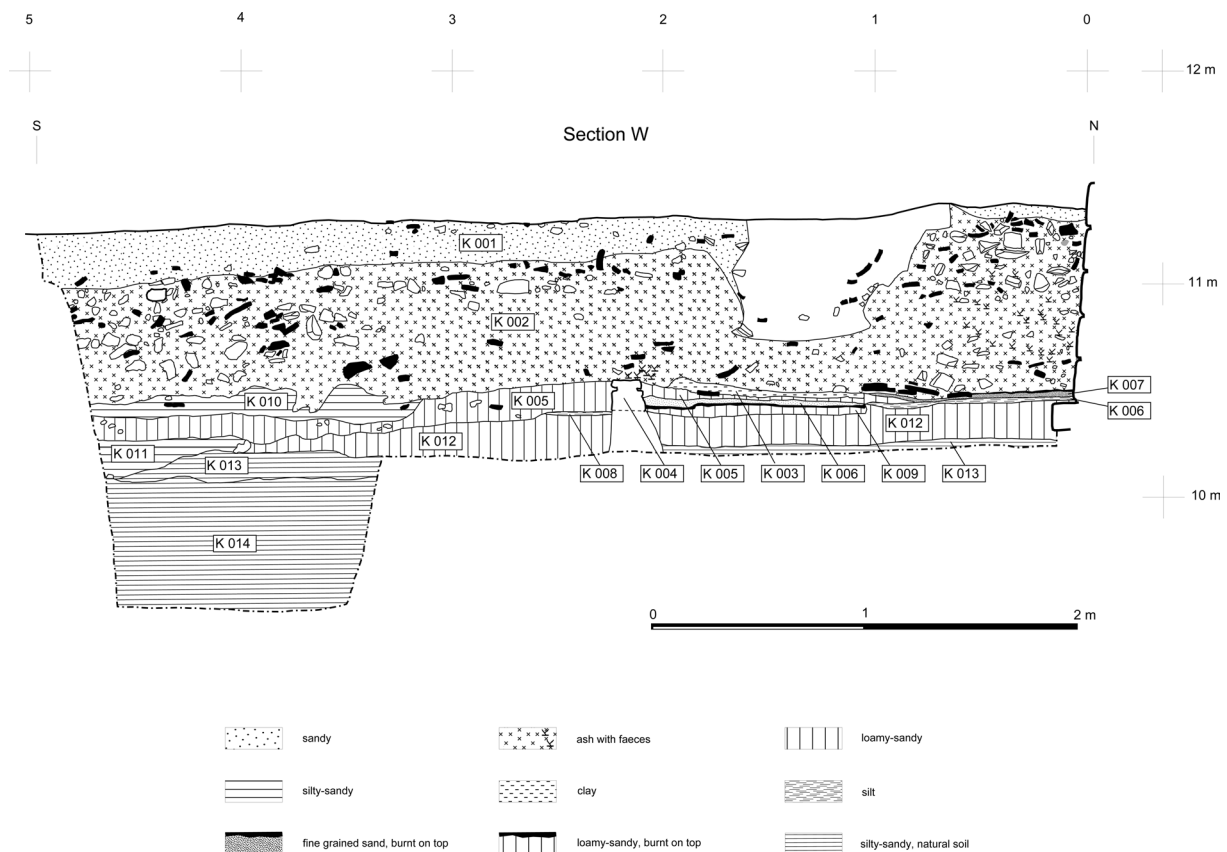

Fig. 2: Western section of trench 224.14, northeastern and southeastern squares (drawing: Claudia Näser, Stephanie Bruck; graphic adaptation: Ralf Miltenberger)

It can now be advanced through the integration of the 1997 data with the findings from the current investigation.

During the 2014 season, a trench was laid out west of 224.12 in order to trace the deposit's extension, recover further sherd material, secure – if possible – samples for dating, and obtain conclusive stratigraphic data. Leaving a 1m-bulk, another 5 x 5m square was laid out and internally subdivided into four 2 x 2m squares with a 1m-bulk between them. Excavation commenced in the northeastern square and later expanded into the southeastern square, with the bulk being finally removed. Due to the undiminished extension of the deposit and the accordingly high volume of finds recovered, the two western squares were not excavated.

The deposit [224.14-002] appeared directly underneath a topmost layer of windblown sand [224.14-001] (fig. 2). It was dumped against wall 224/N where it was c. 80cm thick. Towards the south it became shallower, but was still 50-55cm thick at the southern edge of the trench, compared with only 40cm in trench 244.12 to the east.<sup>7</sup> The matrix of the deposit



Fig. 3: Excavating trench 224.14 (photograph: Claudia Näser)

consisted of extremely loose dusty grey ash, mixed with plenty of finds. This consistency made excavation difficult (fig. 3), thus the decision was taken to proceed in artificial layers of c. 20cm depth. On average, 1000 sherds were recovered per square meter of deposit. Other finds included numerous sandstone fragments,<sup>8</sup> highly fragmented animal bones,<sup>9</sup> sever-

7 Edwards 1999: fig. 6.

8 Their concentration seemed to be somewhat lower than in 224.12; cf. Edwards and Onasch in Edwards 1999: 10. Also, there were no conspicuous signs of burning on them.

9 See Nolde, this volume.



al concentrations of faeces, and some assorted objects, including two mushroom-shaped ceramic objects and two stamps used for decorating pottery. While the matrix was similar throughout the deposit, some internal differentiation was evident in the differing quantities of pottery and stone, and several lenses with high concentrations of animal dung, which were sampled individually. While such features apparently represent individual dumping episodes, they were too rare to obtain a coherent idea about the accumulation process of the deposit. Of interest in this respect is the absence of any lamination or sandy layers within the deposit, which would testify to aeolian and fluvial impacts.<sup>10</sup> Vice versa, there are no compacted layers of sherds or other find material which might indicate the aeolian removal of ash from the deposit. Thus, the overall nature of the deposit – including its wide horizontal extent – remains an enigma.

The deposit covered stratigraphically older contexts, the most prominent feature of which was a mudbrick wall [224.14-004]. Built in a single row of stretchers, it butts onto the northern enclosure wall 224/N at an obtuse angle and turns towards the west at a right angle after 2.5m, enclosing a quadrangular space at the foot of wall 224/N (fig. 4). Since the wall was only two bricks high and no substantial collapse was found, it either must have been a low construction or was torn down deliberately in antiquity with the excess material being removed. The bricks of the wall appear to have experienced secondary burning, and some of their mud was ‘washed’ down to the west of the wall, blending into a reddish loamy-sandy layer of

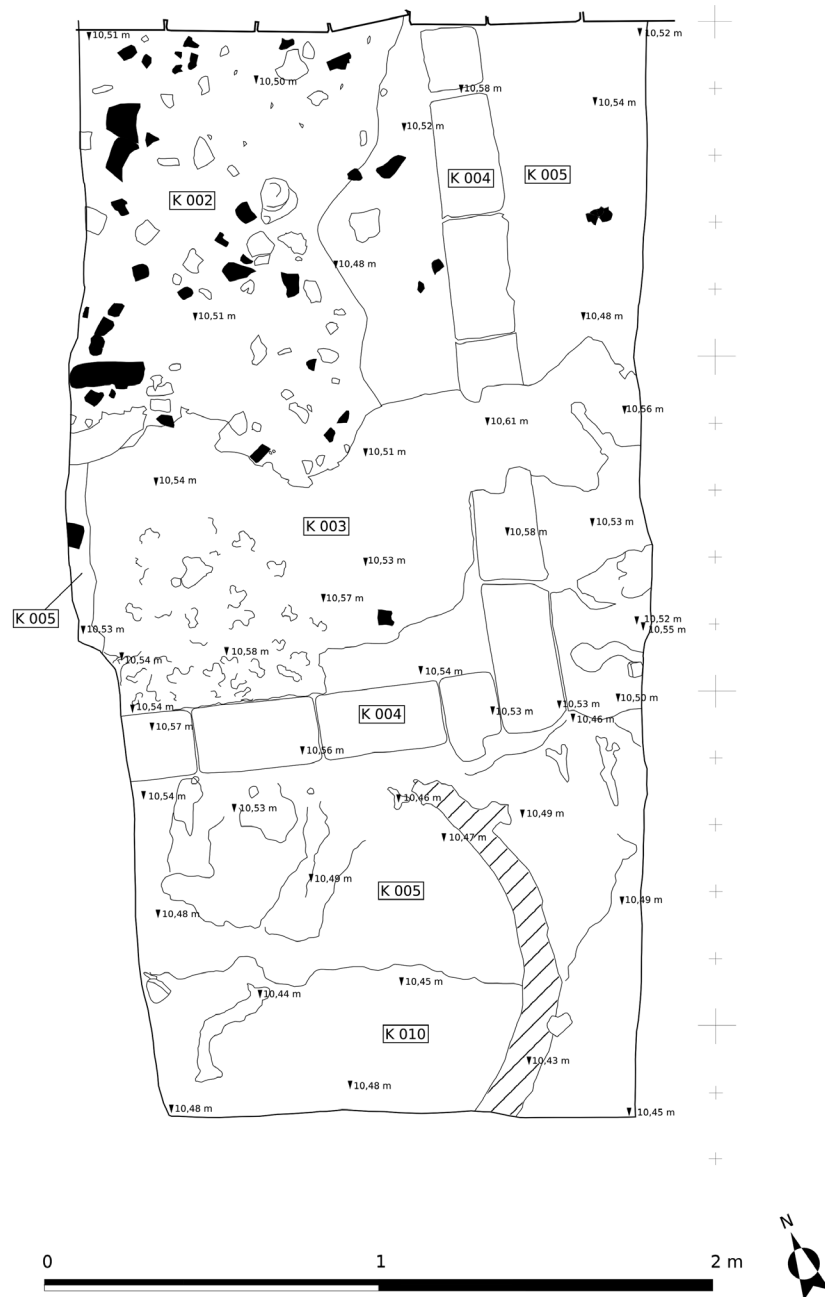

Fig. 4: Plane 2 of trench 2014.14 with the lowest part of the main ash deposit (context 2014.14-002) and the mudbrick wall (context 2014.14-004), overlain/overlain by the packing of unfired clay (context 224.14-003) (drawing: Manja Wetendorf, Stephanie Bruck; graphic adaptation: Ralf Miltenberger)

unclear origin [224.14-005]. In the space enclosed by the wall, i.e. the structure’s ‘interior’, at least two floor levels of compact light grey silt [224.14-006, 224.14-008], separated by thin layers that show localised burning [224.14-007, 224.14-009], could be differentiated (figs. 2, 5, colour fig. 3). The burnt layers can be associated with the traces of localised burning that affected wall 224/N in several places, colouring individual areas from dark ochre to black

10 Dito already Edwards 1999: 37.



Fig. 5: Plane 3 of the northeastern square of trench 2014.14 with the mudbrick wall (224.14-004) and the lower layer with traces of circumscribed/localised burning (224.14-009) (photograph: Claudia Näser)

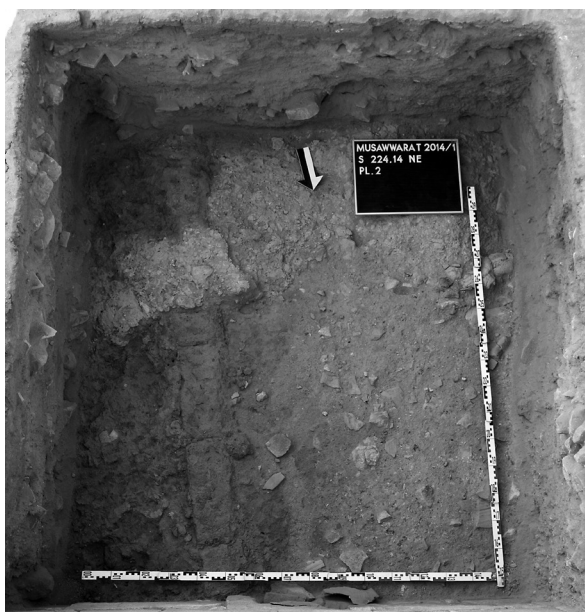

Fig. 6: The packing of unfired clay (context 224.14-003) drawing over the mudbrick wall (224.14-004) (photograph: Claudia Näser)

and even leading to the destruction of several block surfaces.<sup>11</sup> The brick wall was apparently founded on the lower floor layer [224.14-008], though due to the limited extent of the exposed area, this strati-

graphic relationship could not be finally confirmed. East of the brick wall there was a layer of compacted mud with a consistency similar to that of the wall,<sup>12</sup> but with no individual bricks recognisable. The wall rested directly on a loamy-sandy layer, which might be identical to either [224.14-005] or [224.14-012]. The situation corresponds to findings from neighbouring trench 224.12, namely a “thin spread of clean fine mud [...] across the west side of the trench. This had a quite well-defined and relatively straight eastern edge, and appears to represent thin accumulations of mud laid over the existing ground surface. Its regular edge remains difficult to explain at present and suggests the possibility that this area was in some way enclosed.”<sup>13</sup>

Interestingly, part of the mudbrick wall [224.14-004] and the loamy-sandy layer [224.14-005] west of it was overlain by an irregular packing of light grey-brown unfired clay [224.14-003] (figs. 4, 6, colour fig. 4). This packing included fragments of unfired vessels as well as diagnostic chunks of clay which result from the removal of material from a work-piece when the vessel is thrown on the wheel (fig. 7).<sup>14</sup> Substantial amounts of such chunks of clay indicate that the packing contained material deriving directly from the turning process of the wheel while throwing the vessel. Again, this layer corresponds to similar findings in neighbouring trench 224.12, namely “a series of small dumps of worked mud/clay ([619-622]) which included numerous fragments of unfired ceramics”.<sup>15</sup> These dumps directly overlay the aforementioned “thin spread of clean fine mud”, and the authors of the original report believed that they were, “almost certainly associated with this mud deposit”,<sup>16</sup> an opinion which may need to be revised in the light of the new findings: in trench 224.14 the clay packing sits on top of the wall stump; it was only deposited after the structure had been demolished or went out of use.

Stratigraphic findings ‘outside’, i.e. south of the brick structure, are more difficult to understand. They consist of several solid layers of silty [224.14-010, 224.14-011] and loamy sand [224.14-005, 224.14-012], which were hard to differentiate. In the southeastern corner of the trench, a pit [224.14-015] was detected. It had been dug into the natural

11 Similar traces have already been noted in wall portions exposed in trench 224.12; Edwards and Onasch in Edwards 1999: 11, fig. 9. While Wenig in Edwards 1999: 6 assumed that they derive from kilns which once stood in these locations, this has been doubted by Edwards 1999: 41. Future research, including investigations into the production parameters of the preserved pottery, shall address the question whether the mudbrick structure has been associated with the firing of pottery.

12 Therefore, it was subsumed under the same context designation [224.14-004].

13 Edwards and Onasch in Edwards 1999: 10. Whether the ground surface has been identified correctly in this case, remains open to debate.

14 Cf. Edwards 1999: 13, pl. 2.9.

15 Edwards and Onasch in Edwards 1999: 10.

16 Edwards and Onasch in Edwards 1999: 10.



Fig. 7: Chunks of clay from pottery production, associated with context 224.14-005 (photograph: Jürgen Dombrowski)

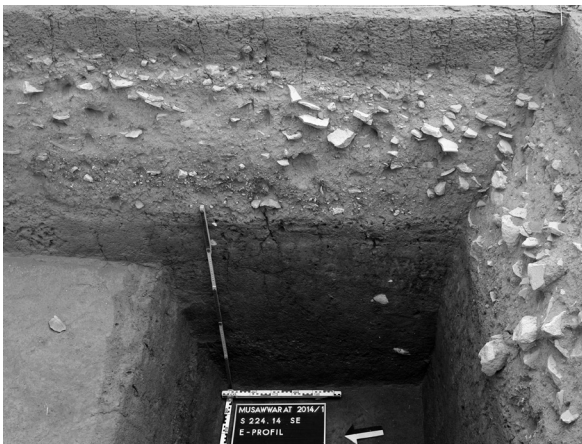

Fig. 8: The eastern section of the southeastern square of trench 224.14 with pit [224.14-015] (photograph: Claudia Näser)

ground [224.14-014] and refilled with material from the surroundings, making it difficult to trace its outlines – accordingly, it was missed in the planum and only recognised in the southern and eastern sections (fig. 8, colour fig. 6). A similar situation was described for trench 224.12 where, in the southwest corner, “an apparently earlier clayey deposit was partially exposed but its significance and origin, whether natural or otherwise, remains unclear”.<sup>17</sup>

17 Edwards and Onasch in Edwards 1999: 8. No context number is mentioned for this feature in the text, but it is probably identical to [634] in *ibid.*: figs. 6, 8, 10. Its stratigraphic position as indicated in *ibid.*: figs. 6, 8 is paradoxical, as it seems to underlie the natural ground [627]. Apparently, there was a general problem in making sense of the findings in this area, as not only the context designations ([627], [628], [634]), but also the matrix attributes (sand, loam, luvisol) of the layers described for southern end of the western section of the trench (*ibid.*: fig. 6, called north-south, east-facing section) and the southern section

In the present excavation the stratigraphic sequence terminates with the natural wadi sediment [224.14-014], which is in part overlain by the typical leached horizon [224.14-013].

In sum, in trench 224.14 we can differentiate seven major occupational events or phases:

- an early phase of use associated with the pit [224.14-015] detected in the southeastern part of the trench
- the construction of the enclosure wall 224/N; its chronological position in relation to the aforementioned phase is unclear
- the construction of the mudbrick structure and its use which was revealed in at least two floor levels and two layers which show circumscribed burning in its ‘interior’
- the final destruction and possible demolition of the structure; the sequence of these events and their specific character are still uncertain
- the dumping of production debris on top of the wall stump
- the deposition of the ash and pottery dump, which probably represents a series of discrete events whose chronological correlation is, however, unknown
- the abandoning of the area, which was subsequently covered with a layer of windblown sand.

Some of these events or phases can also be recognised in the stratigraphic findings from trench 224.12, as discussed above. While the previous investigations produced almost no datable material,<sup>18</sup> numerous <sup>14</sup>C samples could be procured from the current excavations. So far, five dates have been obtained:

(*ibid.*: fig. 8, called east-west, north-facing section) do not correspond.

18 In passing, Edwards 1999: 40 mentions two <sup>14</sup>C dates “acquired from charcoal samples at the base of the ash dumps, material which seemed unlikely to be directly associated in any way with the pottery manufacturing debris”; no laboratory number or any other details are quoted for these dates. They point to the early third century AD, a surprising result which Edwards connects with the assumed re-dumping of the deposit in this period. The present results contradict these dates the contextualisation of which will therefore need to be reviewed in future investigations. On typological grounds, Edwards 1999: 40–41 dates the pottery corpus from trench 224.12 to the first century AD.

Poz-63076 (MUSA2014/1\_IA-224.14-015-001: pit):  
**2170 ± 30 BP**

68.2% probability 352BC (40.2%) 297BC  
228BC ( 3.7%) 221BC  
211BC (24.3%) 176BC  
95.4% probability **360BC (92.9%) 156BC**  
134BC ( 2.5%) 116BC

Poz-63330 (MUSA2014/1\_IA-224.14-009-001:  
layer with traces of burning, 'inside' the mudbrick  
structure): **2020 ± 30 BP**

68.2% probability 50BC (68.2%) 22AD  
95.4% probability **107BC (95.4%) 59AD**

Poz-63158 (MUSA2014/1\_IA-224.14-004-001: col-  
lapsed mudbrick material, west of wall): **1955 ± 30 BP**

68.2% probability 8AD (68.2%) 78AD  
95.4% probability **38BC (89.1%) 90AD**  
100AD ( 6.3%) 123AD

Poz-63077 (MUSA2014/1\_IA-224.14-005-001: loa-  
my-sandy layer under a layer of light clay, i.e. debris  
of pottery production): **1975 ± 30 BP**

68.2% probability 18BC ( 2.7%) 14BC  
1AD (65.5%) 65AD  
95.4% probability **45BC (95.4%) 80AD**

Poz-63159 (MUSA2014/1\_IA-224.14-002-005: ash  
deposit, lower part): **2010 ± 30 BP**

68.2% probability 45BC (68.2%) 25AD  
95.4% probability 92BC ( 4.2%) 68BC  
**61BC (91.2%) 65AD**

Poz-63076 dates the earliest phase of use of the area, evident in pit [224.14-015], from the 4<sup>th</sup> to the 2<sup>nd</sup> centuries BC. All other dates cluster around the 1<sup>st</sup> centuries BC and AD. Poz-63330, which derives from layer [224.14-009] and is thus associated with the use-life of the mudbrick structure, seems to give a slightly earlier date than the other three samples which come from the collapsed brick material of the wall [224.14-004], from layer [224.14-005] between this material and the raw material of the pottery production [224.14-003] drawing over the wall, and from the lower part of the main deposit [224.14-002]. The dates indicate that these contexts are chronologically closely related – and probably represent one extended period of pottery production with shifting activity zones in courtyard 224.

A more comprehensive evaluation of the individual features and phases, particularly the brick wall and the associated occupation floors, will have to wait for further excavations. Still, the data obtained in the current season does, for the first time, provide a firm chronological frame for the pottery produc-



Fig. 9: The workplace of the pottery project in the dighouse complex (photograph: Stephanie Bruck)



tion in courtyard 224, and thus also for the corpus of pottery which will be discussed in the following section.

#### THE POTTERY

From the current excavation of trench 224.14, about 9000 sherds with a total weight of 365 kg were recovered, of which 10% are fineware. All 'feature'/diagnostic sherds (rims, bottoms, decorated fragments) were recorded in a database, except very small pieces (less than 2cm) which were only counted and described. The c. 7000 undiagnostic coarse ware sherds were sorted by fabric and then counted and weighed. They amount to a total weight of 323 kg (fig. 9, colour fig. 7).<sup>19</sup>

In all categories (fine and coarse ware), the variety of shapes is quite limited. This may not be the result of a suboptimal identification of shapes due to the high degree of fragmentation, but more likely reflects a circumscribed inventory of locally produced vessels.<sup>20</sup> Nonetheless, some new shapes and decorative

motifs could be added to the corpus from trench 224.12 presented by Edwards.<sup>21</sup> Since no complete vessels have been found – there are rim sherds, comparatively few fragments of bottoms and a large amount of decorated wall fragments – no overall shapes could be identified.<sup>22</sup>

Excavation of the main deposit was carried out in three artificial layers of c. 20cm depth each. While more than half of the fineware sherds were recorded in the upper two layers, the wheelmade coarse ware was more evenly distributed throughout the deposit. In contrast, the handmade coarse ware sherds almost exclusively derived from the lowest layer of the deposit; only one single sherd was recovered from the topmost layer of windblown sand (table 1), where it may be an intrusion. Some of the handmade coarse ware sherds show traces of overfiring. In contrast, the vast majority of the other pottery from the main ash deposit does not show any signs that might classify them as wasters. This finding is in clear contrast to the overall impression which Edwards described for the corpus from trench 224.12.<sup>23</sup>

#### Distribution of ware groups

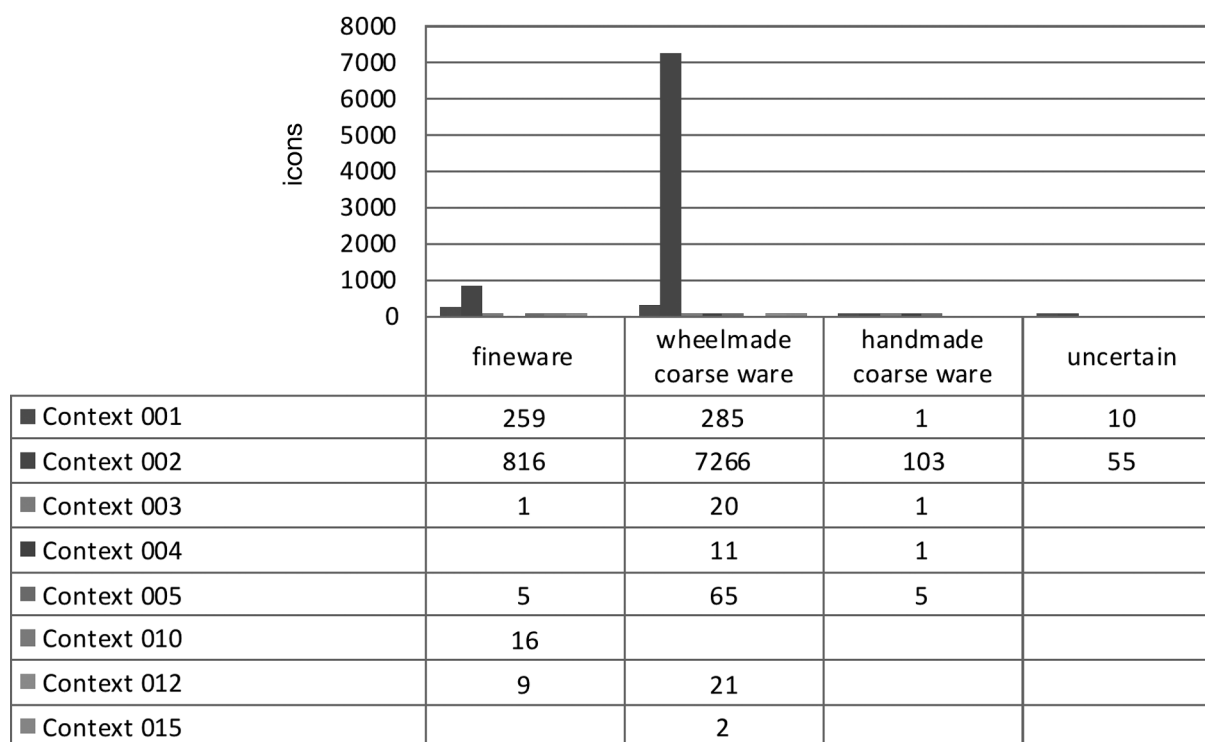

Table 1: Distribution of ware groups within the stratigraphic contexts of trench 224.14 (compilation: Manja Wetendorf)

19 The diagnostic coarse ware sherds, amounting to c. 1000 pieces, are still to be added to this statistic.

20 The absence of certain form groups from the Musawwarat pottery corpus as compared to shapes known mainly from Lower Nubia has already been noted by Otto 1967: 29.

21 Edwards 1999: 14–99.

22 A similar preservation pattern has already been recognised by Edwards 1999: 16–17, although the corpus from trench 224.12 also included some near-complete vessels, e.g. *ibid.*: pls. III, ZN 797, V, ZN 801, XI, ZN 900, VII, ZN 732–734.

23 Edwards 1999: 37–38.



The vast majority of the pottery came from the main ash deposit [224.14-002] and the topmost layer of windblown sand [224.14-001] (table 1). The material from the layers underneath the deposit – with the exception of contexts 224.14-004 and 224.14-005, from which some feature sherds of wheelmade coarse ware were recovered – is highly fragmented and the reconstruction of vessel shapes is impossible. Therefore, statements about the chronological sequence within the overall corpus are hard to make at the present stage of the analysis. Progress in this regard is expected from the ongoing analysis of the coarse ware fabrics.

### *Forms and decorative motifs*

#### *Finewares*

Fineware pottery, comprising some 1000 sherds, is mainly present as decorated wall fragments. Bowls are the most frequent form group, besides a few cups/goblets and small bottles. The vessel shapes are simple – with plain rounded rims, rounded bottoms and short necks on small bottles. The surfaces of the fineware vessels are frequently slipped – colours vary from white to cream and a light pink; some vessels also have a red slip and on rare occasions a yellow or orange slip. While the red slipped specimens seem to be more evenly distributed through the deposit, the rarer orange and yellow slipped sherds derive from the lower parts of the deposit only, with the exception of one sherd, which was recovered from the topmost layer of windblown sand.<sup>24</sup> Only some pieces preserve polishing – but due to the partly heavy erosion of the surfaces, these data are not representative.

Stamped decoration is – as far as the shapes can be determined from the sherds – restricted to bowls.<sup>25</sup> It is commonly used in combination with painted decoration, namely single or double lines and even incised lines bordering the stamped area. The stamped area is almost always restricted to the upper third of the vessel, no overall stamped decoration was documented.<sup>26</sup> Most of the recorded stamp motifs

are well-known from other Meroitic sites and include uraei with sun discs, stylised uraei (?), a standard (whose lower part looks like a lotus flower) framed by two uraei with sun discs, a ‘crowned’ ankh sign, ankh signs (minimum of three rows), crosses or stylised ankh signs (minimum of three rows), crescents (minimum of three rows), sa-knots, several rhomboid forms, an oval motif that looks like a beetle, and some unclassified motifs – probably animals, which mostly appear as simple ovoid shapes (fig. 10). This corpus accords with the more general observation that the range of motifs on stamped fineware from Upper Nubian sites is much more diversified, while the decorative repertoire on specimens from Lower Nubia is much more limited and heavier in Egyptian elements.<sup>27</sup>

Painted decoration without stamps occurs on all vessel forms present in the corpus. Motifs are frequently framed by lines – single, double or rarely more than two lines. Floral designs are common, and there are also geometric patterns, e.g. a chess board motif. On at least one bottle and several cups, the painting seems to extend all over the body (fig. 11).

#### *Wheelmade coarse wares*

The vast majority of the material – more than 7500 sherds – is made up of wheelmade coarse ware. The most common shapes are different types of jars, bowls, lids and small dishes. The jars can be subdivided into large open jars with wide mouths and mostly squared rims,<sup>28</sup> closed jars without or with slightly flaring rims, beer jars and bottles. Vessel surfaces can be slipped, with red being the dominating colour, though it sometimes reveals an orange tint. On some examples the slip occurs in combination with a polish. Bowls can be subdivided into large bowls with sloping sides or slightly flaring rims, bowls with ledged rims,<sup>29</sup> bowls with incurved rims<sup>30</sup> and bowls and dishes with squared rims.<sup>31</sup> The most common vessel bases are rounded or conical bottoms which probably belong to beer jars.<sup>32</sup> A small number of

might extend closer to the bottom part.

24 This statistic is based on the diagnostic material recorded in the database only.

25 In contrast, Edwards 1999: pl. 4.19 shows a stamped fragment, which he thinks is part of a bottle. The current material includes a sherd with a very similar stamp motif (cross or stylised ankh sign), which comes from a bowl. Edwards 1999: pl. XI, ZN 307B, 853 also recorded two cups with stamped decoration. Cf. Seiler 1999: 63 for the operational procedure of stamped decoration.

26 There are only two exceptions where the stamped area

27 See, e.g. Williams 1991: 59–60, table 9, and cf. Shinnie and Bradley 1980: figs. 53–57; Török 1997: e.g. figs. 86, 98, 104 and Dittrich 2003: fig. 7.

28 Cf. Otto 1967: 28, type XII, fig. 19; Edwards 1999: pls. I–II; Seiler 1999: figs. 45, 4.1.4, a.1–a.3 and Dittrich 2003: fig. 4.6.

29 Also well-known from Meroe, cf. Shinnie and Bradley 1980: figs. 30.30, 31.40–41.

30 Cf. Shinnie and Bradley 1980: fig. 32.52.

31 Cf. Edwards 2012: figs. 4.28–7.

32 Cf. Edwards 1999: 25.



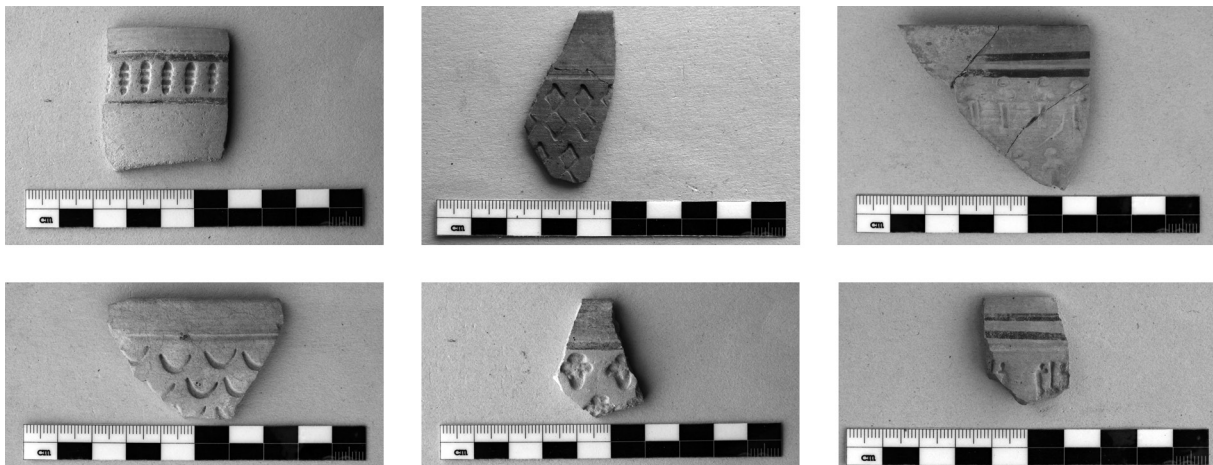

Fig. 10: Examples of stamped decoration on fineware (photographs: Jürgen Dombrowski)



Fig. 11: Examples of painted decoration on fineware (photographs: Jürgen Dombrowski)

flat and ring bases representing other vessel shapes also occur in the material. The differentiation between lids and small dishes is not always certain.<sup>33</sup> A surprise is the absence of clearly identifiable offering stands. There is only one fragment which may represent part of an offering stand, similar to the bowls with squared rims.<sup>34</sup>

Within the wheelmade coarse wares two types of decoration can be noted: painted and incised decoration. Painted designs commonly appear as bands framed by black lines with a white filling; in some cases several lines or ornaments are situated within the band. Painted bands are characteristic features on the shoulder zones of beer jars and bottles. Some shoulder fragments have painted decorations the motifs of which cannot be clearly identified (fig. 12).

33 Cf. Edwards 1999: pl. VIII.

34 Cf. Edwards 1999: pl. V, ZN 779, 781 and the offering stand *ibid.*: pl. IX, ZN 785.

A very common design on big bowls is simple bounded incised lines near the rim; these lines can be on the interior and/or on the exterior of the vessel. Incised wavy-lines framed by a band of one or several lines are a typical decoration of jars (fig. 13).

In sum, both the coarse and the fine wheelmade wares have a relatively limited variety of shapes. They comprise a range of open bowls and large open jars, as well as a few bottles, beer jars, dishes and lids for the coarse wares; and bowls, cups/goblets and few specimens of small painted bottles for the finewares. The individual vessel forms are generally well-known from other Meroitic sites and essentially reflect the repertoire which has already been presented by David Edwards. Amazingly, there are no securely identifiable incense burners and offering stands, despite the fact that they would clearly be expected at a site like Musawwarat. Future studies will have to evaluate this result and should, for example, focus on different forms of bowls to learn whether they



Fig. 12: Examples of painted decoration on wheelmade coarse ware (photographs: Jürgen Dombrowski)



Fig. 13: Examples of incised decoration on wheelmade coarse ware (photographs: Jürgen Dombrowski)

might have been parts of offering stands as Edwards assumed for some large bowls from trench 224.12.<sup>35</sup>

#### *Handmade coarse wares*

Only a few vessels belong to this group; they include bowls with plain rounded rims and closed jars with plain rims. While the jars are undecorated, the bowls bear incised and impressed decoration (fig. 14). Comb impressions are a distinct decorative motif, which is exclusively related to handmade wares. Vessel surfaces are usually well smoothed or polished, and very rarely covered by a slip.

#### *Fabrics*

The analysis of the fabrics was based on the results of the archaeometric study of 2013, which was conducted on 39 samples from the sherd material of the 1997 excavation of trench 224.12.<sup>36</sup> This series indicated that all samples consist of ceramic bodies sourced

from the same geological region and should therefore represent a local production. The classification of the finewares in several MGR/fabric-groups was successfully adopted in the current analysis of the material from trench 224.14, which is now at an advanced stage. All finewares from Musawwarat are made from kaolinitic clays with a high iron content; variations in colour are due to the different mixtures of the clays used.<sup>37</sup> Macroscopically it is difficult to distinguish the different fabric groups; even shapes, surface treatments and types of decoration do not provide safe criteria for a distinction (figs. 15–18).

The analysis of 20 coarse ware samples revealed that these were made from wadi clays, which are low in potassium and tempered with varying amounts of conglomerates of quartz. 19 samples belong to the same main group. This group also dominates the current material from trench 224.14 (figs. 19–20). As no samples of handmade coarse wares were analysed in 2013, special attention was given to this group in the current season. It was already clear in the field that the handmade wares were produced from different materials. A preliminary fabric system with four main groups and three sub-groups was established.

35 Edwards 1999: 23, 38.

36 See Näser and Daszkiewicz 2013. One other object from the same location and four comparative samples from other contexts were also analysed in this study.

37 For a more in-depth discussion see Näser and Daszkiewicz 2013: 15–22.

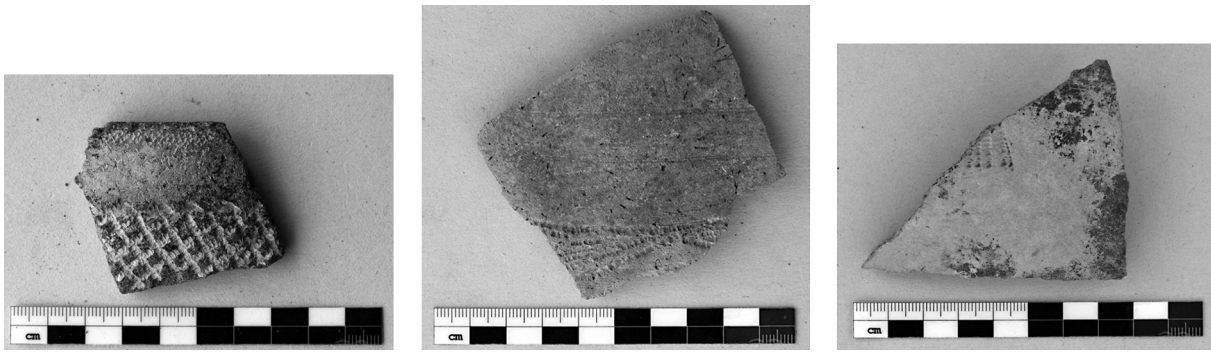

Fig. 14: Examples of impressed and/or incised decoration on handmade coarse ware (photographs: Jürgen Dombrowski)

To evaluate this system as well as the fabric system of the wheelmade coarse wares, further archaeometric analyses were initiated. The first results confirmed that the majority of the wheelmade coarse wares were made from ceramic bodies of similar chemical and mineralogical composition, and should be associated with local production. The handmade coarse ware specimens (with the exception of two fabrics) were probably not locally produced, but came from elsewhere (fig. 21).<sup>38</sup> Future studies will evaluate this result and investigate the position of the identified groups in the overall ceramic corpus from Musawwarat.

#### OTHER FINDS

While pottery constituted the vast majority of the finds recorded from trench 224.14, some other items also deserve attention. From most contexts ([224.14-001] to [224.14-005] and [224.14-010], [224.14-012], [224.14-015]), low quantities of mostly very fragmented animal bones were recovered. Among the bones which were of sufficient size for species determination, cattle was predominant.<sup>39</sup> Pig, sheep, gazelle, an equide and a bird were been identified. A puzzling finding is two fragments of human calvaria, which derive from the central part of the main deposit [224.14-002]. While some of the animal bones have been partly charred or otherwise show the impact of fire, the majority show no trace of burning. The faeces, which were found in several smaller and larger concentrations throughout the deposit [224.14-02], deserve a special mention.<sup>40</sup>

38 For detailed data see Daszkiewicz and Schneider, this volume.

39 For this and the following data in detail, see Nolde, this volume.

40 Dung has also been recorded from the deposit in trench 224.12; cf. context sheets [615], [618], [619] in the Musawwarat archive.

Scientific species determination is still pending, but they have provisionally been identified as cattle dung with the assistance of the local excavation staff. While numerous samples of these faeces have been taken for <sup>14</sup>C dating, a first dating attempt (Poz-63309) failed completely, possibly due to limited carbon content. A detailed investigation of this problem is sought with our partner, the Poznan Radiocarbon Laboratory. One step in this endeavour will be to ascertain the preservation state of the faeces. They display a more or less fragile, parchment-like consistency, as if they have been burnt to differing degrees – though in which context exactly, remains to be established.

Further finds from the deposit include a few pieces of slag, which are currently awaiting archaeometric analysis, a pottery bead (fig. 22), a rim sherd from a small faience bowl (fig. 22), a stone ball, two enigmatic mushroom-shaped pottery objects (fig. 23),<sup>41</sup> a rough potter's stamp (fig. 24)<sup>42</sup> and a near-complete stamp destined for decorating the typical Meroitic fineware pottery with an ankh sign on a crescent (fig. 24).<sup>43</sup> While some of these objects are clearly associated with pottery production, it will be interesting to find out what the function of the pottery mushrooms may have been.

41 Cf. object <615-2> from trench 224.12; Edwards 1999: 13, fig. 12. The parallel from Meroe which Edwards quotes (Shinnie and Bradley 1980: fig. 83, no. 928) is not very similar to the much cruder objects from Musawwarat which do also not display a stamp motif on the surface supposedly destined for sealing. Indeed this surface is not level, but slightly undulated in the current specimens. Therefore, it seems unlikely that these objects were stamps.

42 This specimen is larger, and cruder, than the ones recovered from trench 224.12 (Edwards 1999: 12–13, fig. 12, pls. 1.5–6, 2.7), but it also seems to display a stamp motif, probably an ankh sign.

43 For the latter cf. Edwards 1999: 12–13, fig. 12, pls. 1.5–6, 2.7. Again the comparisons from Meroe cited by Edwards (Shinnie and Bradley 1980: 190–191, figs. 83–84) are not good parallels.

**Chemical group 1** Fabric C1 (MGR 95)**Chemical group 2** Fabric C2 (MGR 96)

Fig. 15: Examples of fineware shapes classed by fabrics: C1 and C2 (drawings: Manja Wetendorf, Stephanie Bruck; graphic adaptation: Manja Wetendorf)

**Chemical group 3** Fabric C3 (MGR 97)

Fig. 16: Examples of fineware shapes classed by fabrics: C3 (drawings: Manja Wetendorf, Stephanie Bruck; graphic adaptation: Manja Wetendorf)

**Chemical group 3** Fabric C4 (MGR 98)

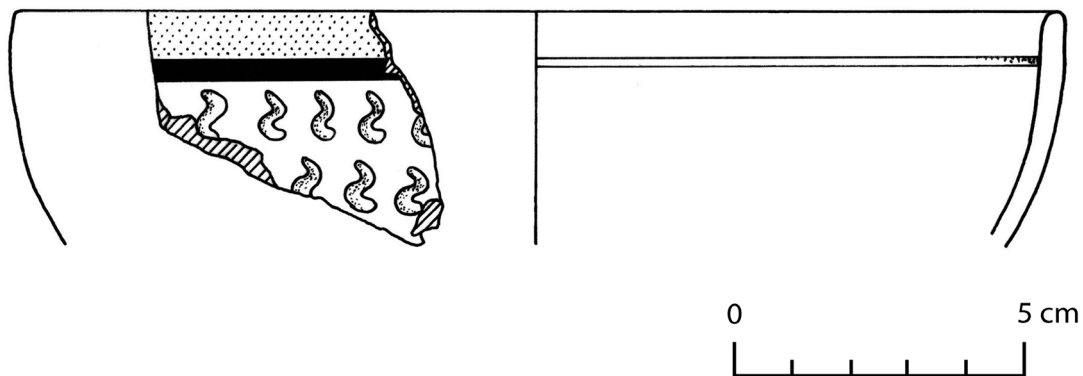
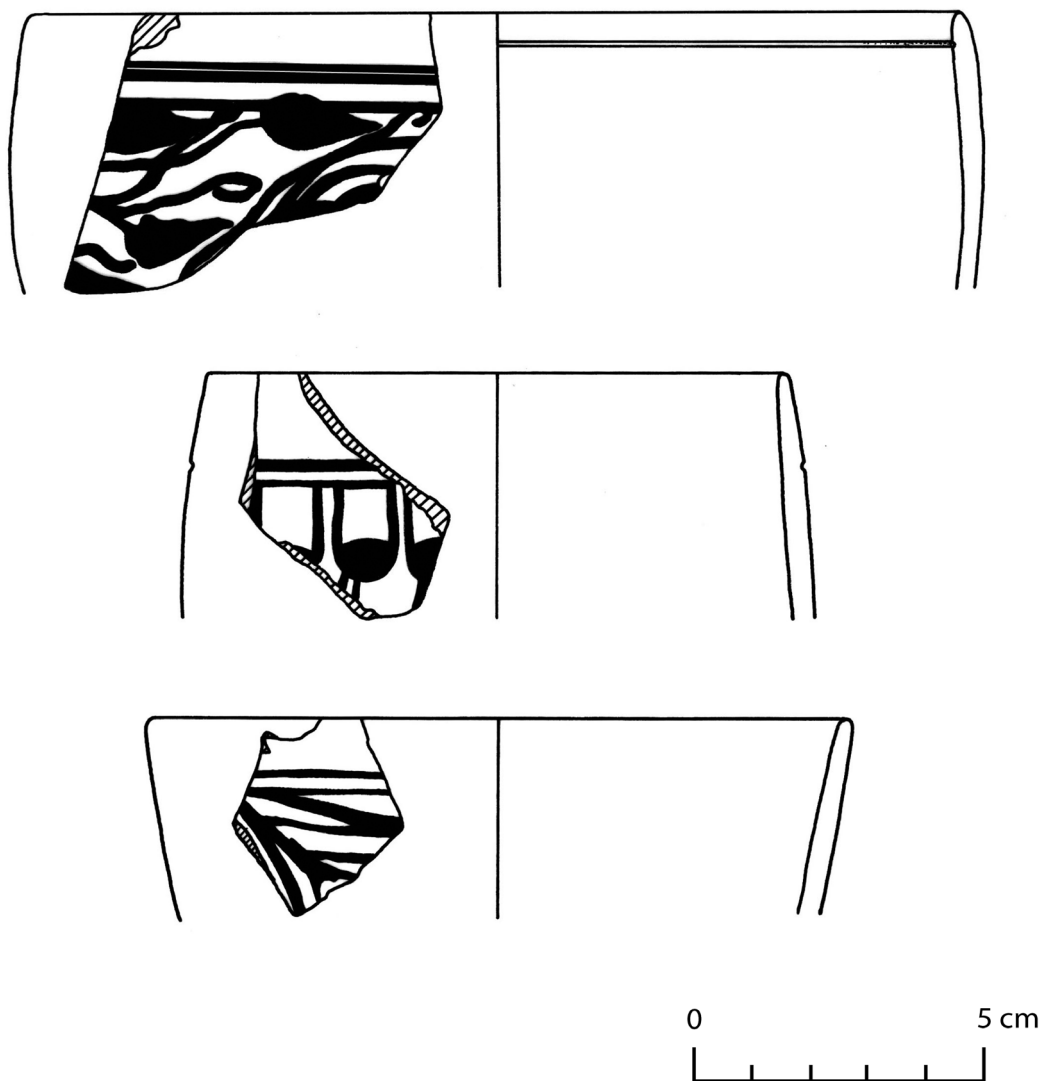
Fig. 17: Examples of fineware shapes classed by fabrics: C4 (drawings: Manja Wetendorf, Stephanie Bruck; graphic adaptation: Manja Wetendorf)

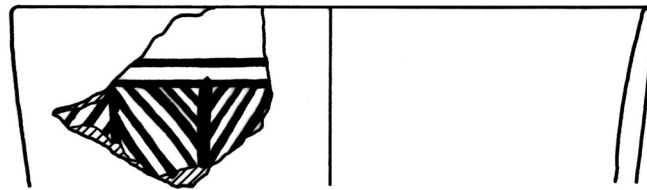
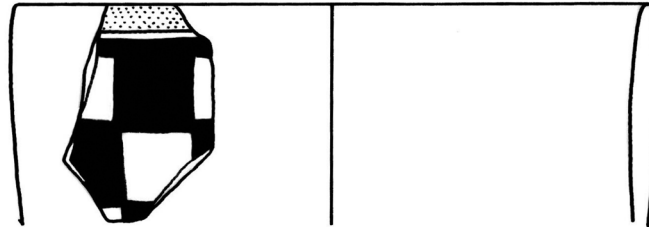
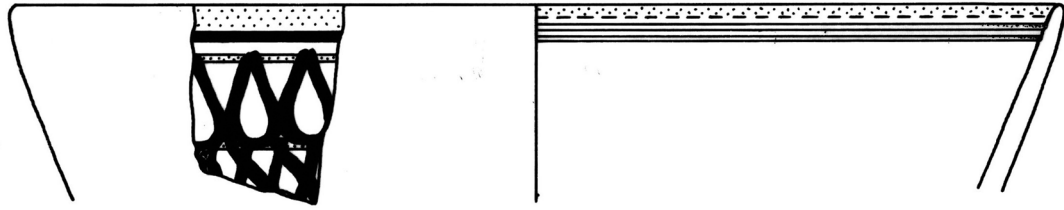

**Chemical group 3** Fabric C5 (MGR 99)

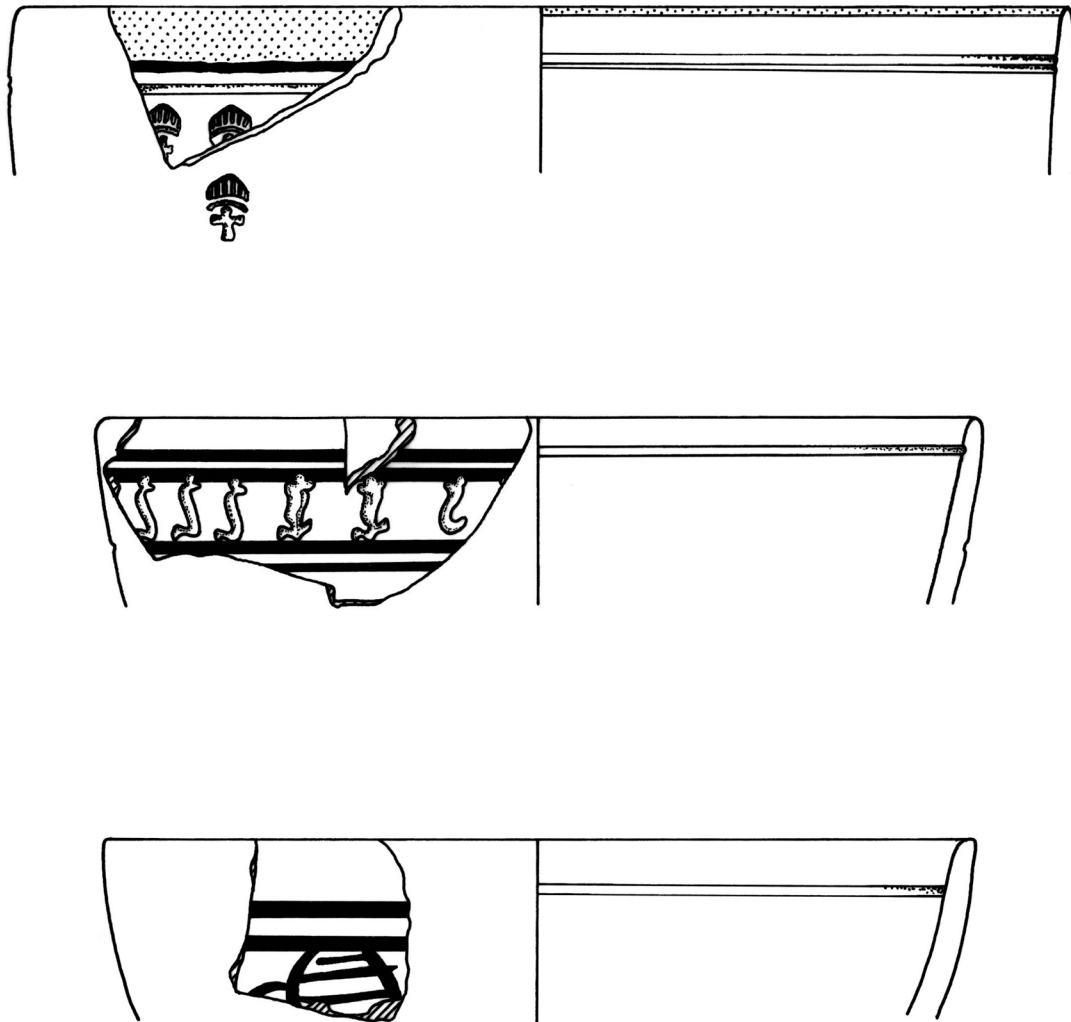
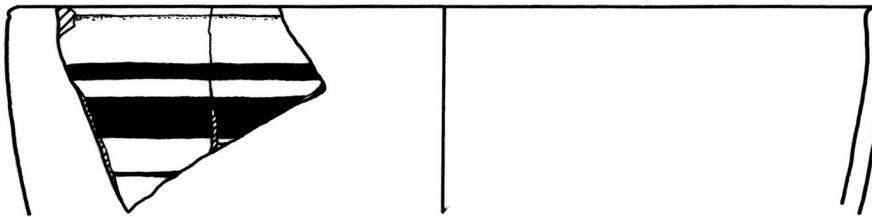
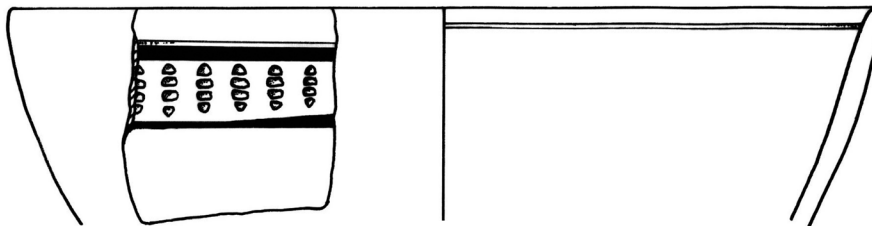
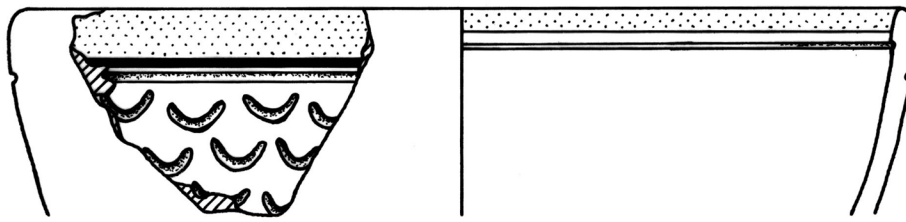

**Chemical group 3** Fabric C6 (MGR 100)

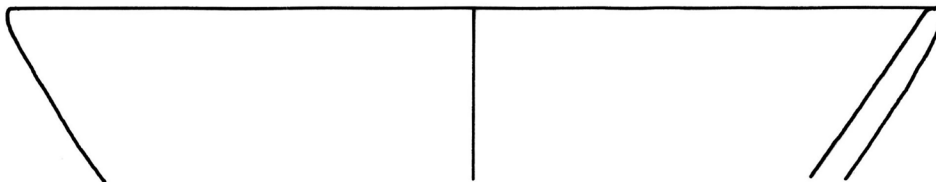

Fig. 18: Examples of fineware shapes classed by fabrics: C5 and C6 (drawings: Manja Wetendorf, Stephanie Bruck; graphic adaptation: Manja Wetendorf)

**Chemical group 4** Fabric H1 and variants (MGR 102, 102.1, 102.2)

Fig. 19: Examples of wheelmade coarse ware shapes classed by fabrics: H1 and variants (drawings: Manja Wetendorf, Stephanie Bruck; graphic adaptation: Manja Wetendorf)



**Chemical group 4** Fabric H1 and variants (MGR 102, 102.1, 102.2)

Fig. 20: Examples of wheelmade coarse ware shapes classed by fabrics: H1 and variants (drawings: Manja Wetendorf, Stephanie Bruck; graphic adaptation: Manja Wetendorf)

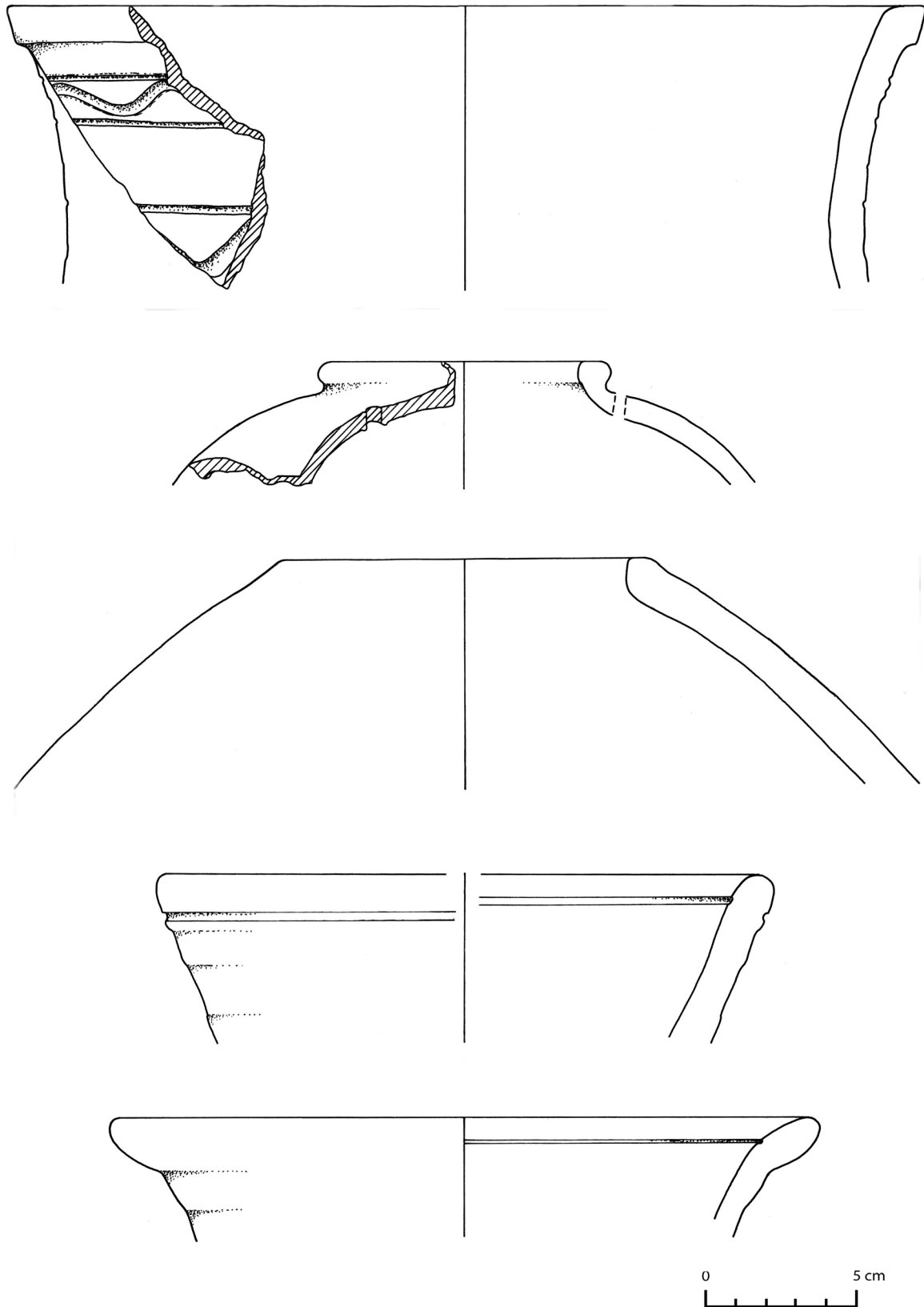

Handmade wares Fabric H7

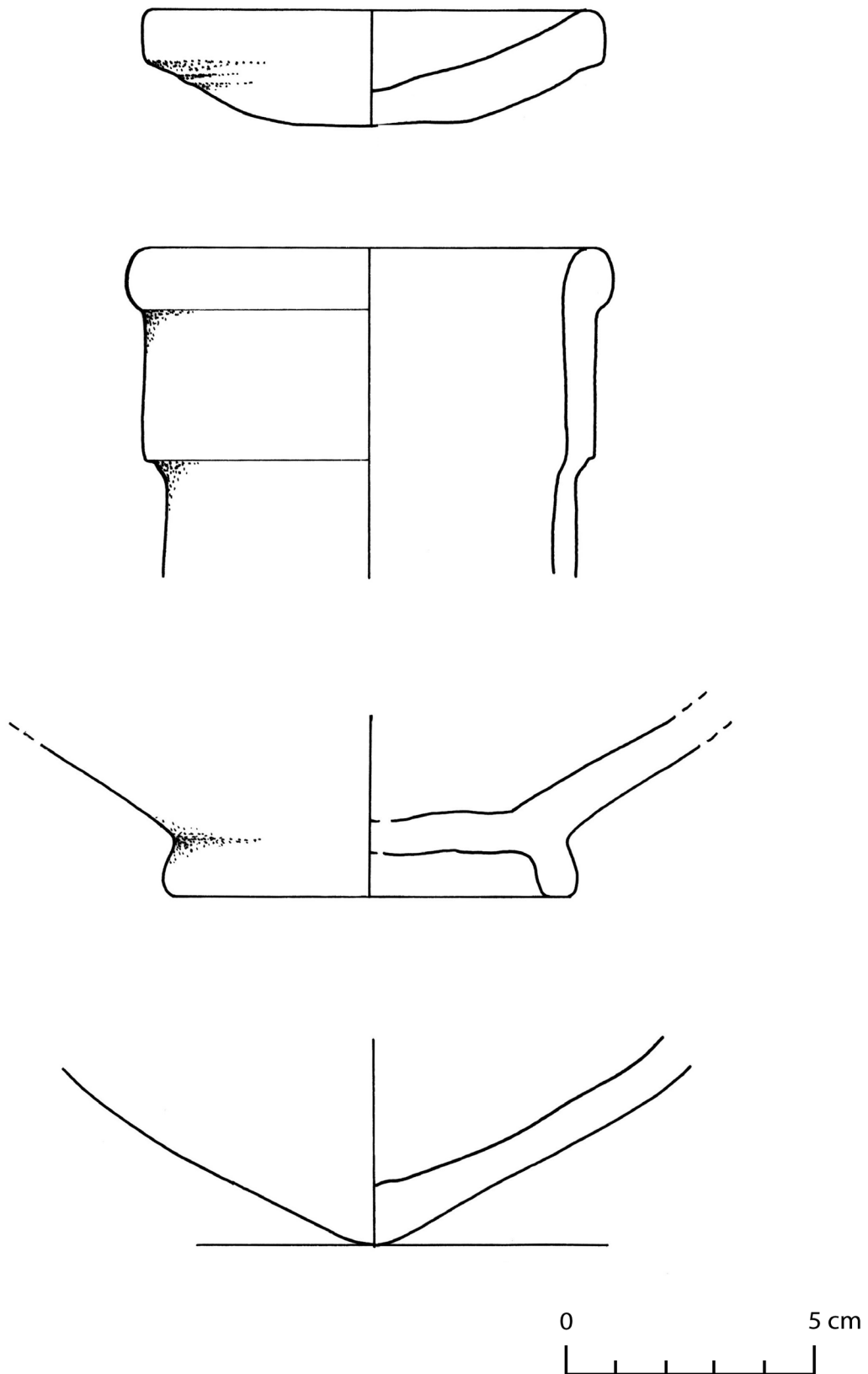
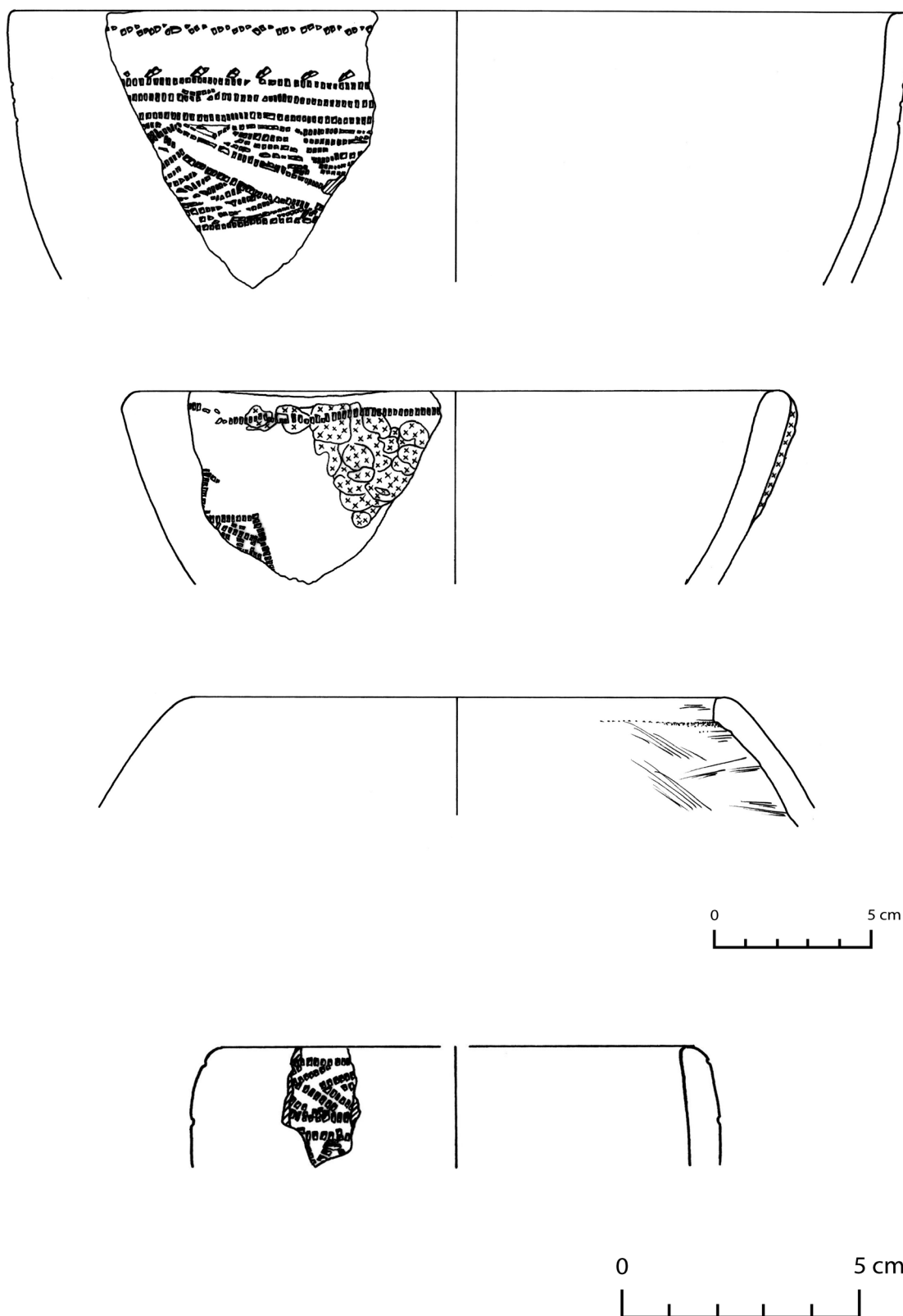

Fig. 21: Examples of not locally produced handmade ware shapes classed by fabric: H7 (drawings: Manja Wetendorf, Stephanie Bruck; graphic adaptation: Manja Wetendorf)

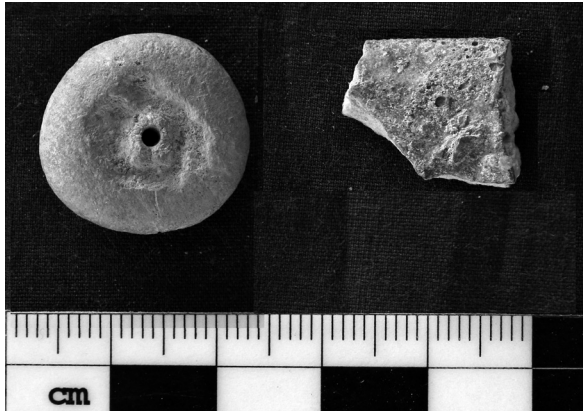

Fig. 22: Pottery bead (find no. 224.14-002-006) and fragment of a small faience bowl (find no. 224.14-002-011) from the main ash deposit [224.14-02] (photographs: Jürgen Dombrowski)



Fig. 23: Mushroom-shaped objects of pottery (find nos. 224.14-002-007, 224.14-002-034) from the main ash deposit [224.14-02] (photographs: Jürgen Dombrowski)

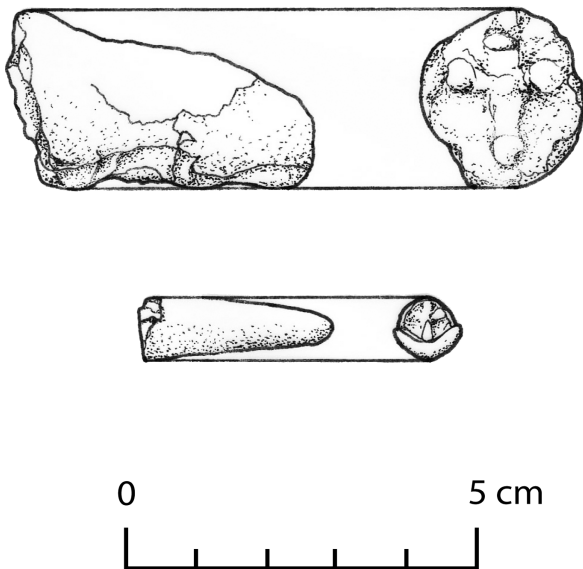

Fig. 24: A rough potter's stamp (find no. 224.14-002-016) and a potter's stamp with an ankh sign on a crescent (find no. 224.14-002-046) from the main ash deposit [224.14-02] (drawing: Stephanie Bruck; graphic adaptation: Manja Wetendorf)

## PERSPECTIVES

The 2014 investigations have significantly enlarged our knowledge about and understanding of 'pottery courtyard' 224. We can now securely date its functioning period – and its concrete production outcomes – to the 1<sup>st</sup> centuries BC and AD. The repeated discovery of raw material and work-pieces, which originate from the very process of throwing the vessels on the wheel indicate a production place in the immediate vicinity. In room 225, in the northwestern corner of courtyard 224, a potter's wheel was found in the 1960s.<sup>44</sup> While it has been assumed that this room was the workshop proper,<sup>45</sup> it could also have been used for storage, with the actual production taking place elsewhere in the open. Thus, one enquiry to be pursued in the coming seasons is to further clarify the zones of activity in courtyard 224 and, if possible, to identify the locus, or loci, of production. This will also include further efforts to establish the extent and the nature of the main deposit [224.14-002].<sup>46</sup>

The stratigraphic sequence recognised in trench 224.14 suggests shifting activity zones within the production context: the exposed area first housed a mudbrick structure, which was eventually abandoned and possibly torn down, whereupon small quantities of production debris were deposited in the area, before it was finally used to hold a major dump. Through its main component – the ash – this final deposit has obvious associations with the firing of pottery, but this supposed nexus also triggers a number of questions. So far no traces of kilns or firing pits have been found in courtyard 224 or its vicinity. While the ash could have been deposited south of wall 224/N to prevent it being blown away by the prevalent northerly winds, its open deposition would still have resulted in considerable amounts of ash in the air, as we experienced during the excavation and during the subsequent refilling of the trench, which was carried out under circumstances which must have been very close to those in antiquity. While we tried to limit the ash fright in the air by the interspersed deposition of layers of sand, no such

44 Edwards 1999: 42, fig. 5, pls. 6.32–34.

45 Wenig in Edwards 1999: 4, 6; cf. Edwards 1999: 38.

46 Contrary to the assertion of Steffen Wenig in Edwards 1999: 4–6, the deposit has not been detected in trenches 2241 and 2242 in the southeastern part of courtyard 224, which had first been excavated by Fritz Hintze in 1965/66 and were reinvestigated and enlarged into trench 224.10 by Hans-Ulrich Onasch in 1999; cf. Hintze 1967/68: 289, plan IV, 1968: plan IV; Onasch 2001: 52–53, fig. 1. Data from these locations remain to be integrated with the current investigations.



measure has been taken in antiquity. Beyond these pragmatic considerations, also the very composition of the deposit raises further questions. While it has been assumed that many if not most of the pottery finds constitute wasters,<sup>47</sup> indications towards this were very limited in the corpus of ceramics recorded in the current season. In contrast, the pottery showed a high degree of fragmentation, which has previously been explained with the suggestion “that the sherds and ash are essentially secondary refuse, having been moved here from a previous location(s)”,<sup>48</sup> with the individual sherds having been displaced in that process. While this hypothesis cannot be ruled out a priori, it has so far found no substantiation in the contexts recovered from trench 224.14. Our observations have instead triggered us to question the relationship between the ash and the other components of the deposit. It may be premature to declare the ash and the pottery as originating from the same source, since it cannot be excluded that the different elements of the dump came from different origins, as is demonstrated for example by the animal bones. Still, the immediate neighbourhood of an area of pottery production is also made plausible by the current findings, not least the stamp with the ankh-on-crescent design which also derives from the deposit and again confirms that Meroitic fineware pottery was locally designed and produced at the turn of the eras. This makes Musawwarat the oldest securely dated locus of production for this type of pottery – a conclusion which certainly calls for further investigations.

## BIBLIOGRAPHY

- Dittrich, A. (2003): Meroitische und spätmeroitische Keramik aus Hamadab, *MittSAG* 14: 77–91.
- Edwards, D. (1998): Report on the Musawwarat pottery, 1997, *MittSAG* 8: 62–67.
- Edwards, D. N. (1999): A Meroitic Pottery Workshop at Musawwarat es Sufra. Preliminary Report on the Excavations 1997 in Courtyard 224 of the Great Enclosure. *Meroitica* 17,2: Musawwarat es Sufra III. Wiesbaden.
- Edwards, D. N. (ed.) (2012): *The Archaeology of a Nubian Frontier*. Leicester.
- Hintze, F. (1967/68): Musawwarat es Sufra. Report on the excavations of the Institute of Egyptology, Humboldt University, Berlin, 1963–1966 (fourth to sixth seasons), *Kush* 15: 283–298.

47 Edwards 1999: 37 – “probably all of the finewares as well as a significant proportion of the coarsewares”.

48 Edwards 1999: 37.

- Hintze, F. (1968): Musawwarat es Sufra. Vorbericht über die Ausgrabungen des Instituts für Ägyptologie der Humboldt-Universität, 1963 bis 1966 (vierte bis sechste Kampagne), *WZHU, Gesellschafts- und Sprachwissenschaftliche Reihe* 17: 667–684.
- Näser, C. and M. Daszkiewicz (2013): New data from the ceramic workshop in courtyard 224 of the Great Enclosure in Musawwarat es Sufra, *MittSAG* 24: 15–22.
- Onasch, H.-U. (2001): Feldarbeiten des Seminars für Sudanarchäologie und Ägyptologie der Humboldt-Universität zu Berlin in Musawwarat es Sufra. Fünfte Kampagne, 20.2. – 31.3.1999, *MittSAG* 11: 51–55.
- Otto, K.-H. (1967): Zur Klassifikation der meroitischen Keramik von Musawwarat es-Sufra (Republik Sudan), *Zeitschrift für Archäologie* 1: 1–32.
- Seiler, A. (1998): Feine meroitische Ware aus Musawwarat es Sufra. Erste Ergebnisse der Bearbeitung der Keramik aus Hof 224 der Grossen Anlage, *MittSAG* 8: 56–61.
- Seiler, A. (1999): Die Keramik – Form und Funktion. In Fitzenreiter, M., *Die Kleine Anlage. Meroitica* 17,1: Musawwarat es Sufra II. Wiesbaden 1999: 53–78.
- Shinnie, P. L. and R. J. Bradley (1980): *The Capital of Kush* 1. Meroe Excavations 1965–1972. *Meroitica* 4. Berlin.
- Török, L. (1997): *Meroe City. An Ancient African Capital*. London.
- Wenig, St. and P. Wolf (1998a): Feldarbeiten des Seminars für Sudanarchäologie und Ägyptologie der Humboldt-Universität in Musawwarat es Sufra. Erste Hauptkampagne, 16.10.1995 – 13.1.1996, *MittSAG* 8: 24–37.
- Wenig, St. and P. Wolf (1998b): Feldarbeiten des Seminars für Sudanarchäologie und Ägyptologie der Humboldt-Universität in Musawwarat es Sufra. Zweite Hauptkampagne, 1.2.1996 – 1.4.1996, *MittSAG* 8: 38–49.
- Wenig, St. and P. Wolf (1998c): Feldarbeiten des Seminars für Sudanarchäologie und Ägyptologie der Humboldt-Universität in Musawwarat es Sufra. Dritte Hauptkampagne, 13.1.1997 – 11.4.1997, *MittSAG* 9: 24–43.
- Williams, B. (1991): *Meroitic Remains from Qustul Cemetery Q, Ballana Cemetery B, and Ballana Settlement*. OINE 8. Chicago.

## ZUSAMMENFASSUNG

Der Beitrag präsentiert die Ergebnisse der diesjährigen Grabungen im ‘Keramikhof’ 224 der Großen Anlage und die vorläufigen Resultate der Analyse der Funde aus diesem Bereich. In dem westlich des Schnitts 224.12 von 1997 angelegten neuen 2 x 5 m großen Schnitt 224.14 setzte sich Aschedeposit in unverminderter Stärke fort. Die in Schnitt 224.14 dokumentierte Stratigraphie belegt sieben Hauptnutzungsphasen des Areals:



- eine frühe Nutzung, zu der eine Grube [224.14-015] im südöstlichen Quadranten des Schnitts gehört
- der Bau der Umfassungsmauer 224/N, deren chronologische Stellung in Bezug auf die vorgenannte Phase noch unklar ist
- die Anlage einer Lehmziegelstruktur und deren Nutzung, von der zwei Fußbodenstraten und zwei Schichten mit Brandspuren zeugen
- die Zerstörung und der mögliche Rückbau dieser Ziegelstruktur; die genaue Abfolge und der Charakter dieser Ereignisse sind noch unklar
- die Deponierung von Ton und Produktionsabfällen auf den Resten der Ziegelstruktur
- die Anlage des Aschedeposits, die vermutlich eine Reihe separater Ereignisse darstellt
- die Aufgabe des Areals, das in der Folge von einer Flugsandschicht bedeckt wurde.

Einige dieser Phasen können mit Befunden aus Schnitt 224.12 korreliert werden. Während jedoch die früheren Grabungen fast kein datierbares Material erbrachten, konnten in der aktuellen Grabung zahlreiche <sup>14</sup>C-Proben geborgen werden. Die bisher fünf daraus gewonnenen Datierungen weisen die erste Nutzungsphase des Areals in das 4. bis 2. Jahrhundert v. Chr. – die vier weiteren Daten, die mit der Nutzungsphase der Ziegelstruktur, den darüber liegenden Horizonten und dem Aschedeposit verbunden werden können, fallen in den Zeitraum vom 1. Jahrhundert v. bis zum 1. Jahrhundert n. Chr. Sie zeigen, dass die genannten Kontexte chronologisch eng beieinander liegen und vermutlich eine längere Phase der Keramikproduktion mit wechselnden Aktivitätszonen in Hof 224 repräsentieren. Damit ist erstmals ein zeitlicher Rahmen für die Keramikproduktion in Hof 224 und für die ihr zugehörigen Funde abgesteckt.

Die Keramik aus Schnitt 224.14 umfasst ca. 9000 Scherben mit einem Gesamtgewicht von 365 kg, von denen ca. 10% Feinware sind. Die Formenvielfalt in diesem Korpus ist begrenzt – dieser Befund scheint das beschränkte Repertoire der vor Ort produzierten Keramik zu reflektieren. Trotzdem konnten gegenüber dem Material aus Schnitt 224.12 einige neue Gefäßformen und Dekormotive erfasst werden. Im Bereich der Feinware sind Schalen die häufigste Formgruppe, hinzukommen einige Becher- und kleine Flaschenformen. Die Gefäße aus Feinware besitzen üblicherweise einen Überzug, der meist cremefarben bis hellpink, selten rot, gelb oder orange ist. Stempeldekoration findet sich im analysierten Korpus nur auf Schalen und umfasst die andernorts belegten Motive. Gemaltes Dekor – vor allem florale und

geometrische Motive – findet sich auf allen Gefäßformen. Bei den Gefäßen aus Grobware handelt es sich vor allem um Krüge, Schalen, Deckel und kleine Teller; überraschend ist das Fehlen von Opferständen. Soweit ein Überzug vorhanden oder erhalten ist, dominiert rot. Dekorationen können aufgemalt, vor allem in Form von Bändern auf der Schulterzone von Bierkrügen und Flaschen, oder eingeritzt, vor allem in Form einfacher Linien im Randbereich großer Schalen und wellenförmiger Dekore auf Krügen, sein. Der Anteil handgemachter Gefäße im Korpus ist gering und auf einfache Schalen- und Krugformen beschränkt. Lediglich die Schalen können geritztes und eingedrücktes Dekor besitzen. Die Bestimmung der Fabrics des vorliegenden Korpus baut auf einer 2013 durchgeführten archäometrischen Analyse von 39 Keramikproben aus Schnitt 224.12 von 1997 auf. Diese Serie hatte gezeigt, dass alle Proben aus Material derselben geologischen Ursprungsregion bestanden und daher eine lokale Produktion repräsentieren sollten. Die Klassifikation der Feinwaren in verschiedene MGR/Fabric-Gruppen wurde in der aktuellen Bestimmung erfolgreich übernommen, wobei sich zeigte, dass eine makroskopische Unterscheidung schwierig sein kann. Bei den Grobwaren dominiert eine 2013 isolierte Hauptgruppe von Waditonon auch das aktuelle Material. Die in der Untersuchung von 2013 nicht erfasste handgemachte Keramik wurde in einer vorläufigen makroskopischen Bestimmung in vier Fabric-Gruppen unterteilt. Die nachfolgende archäometrische Analyse ergab, dass ein substantieller Teil dieser Keramik vermutlich nichtlokalen Ursprungs ist.

Obwohl Keramik die Mehrzahl der Funde aus dem Aschedeposit ausmachte, wurden auch einige andere Objekte geborgen, darunter Tierknochen (siehe dazu den Beitrag von Nolde im vorliegenden Heft) und Dung, der provisorisch als Kuhdung bestimmt wurde, zwei Fragmente menschlicher Schädel, einige Schlackestücke, eine Keramikperle, das Fragment eines Fayenceschälchens, eine Steinkugel, zwei enigmatische pilzförmige Objekte aus Keramik sowie zwei Stempel zur Dekoration von Keramik. Aus den chronologisch älteren Kontexten, d.h. aus den Schichten unterhalb des Aschedeposits, stammen einige Tierknochen und wenig Keramik, die auf Grund des hohen Zerscherbungsgrads in ihrer chronologischen Aussagekraft jedoch beschränkt ist.