



# Reading Mesolithic Human Tracks with a Multi-Method Approach in the Paul Ambert gallery of Aldène cave (Cesseras, Hérault, France)

*Lesen mesolithischer Fußabdrücke in der Paul Ambert Galerie der Höhle Aldène (Cesseras, Hérault, Frankreich) mit einem multi-methodischen Ansatz*

Andreas PASTOORS<sup>1\*</sup>, Tilman LENSSEN-ERZ<sup>†</sup>, Tsamgao CIQAE<sup>2</sup>, /Ui KXUNTA<sup>2</sup>, Thui THAO<sup>2</sup>, Philippe GALANT<sup>3</sup>, Marcel WEIß<sup>1</sup> & Thorsten UTHMEIER<sup>1</sup>

<sup>1</sup> Friedrich-Alexander-Universität Erlangen-Nürnberg, Institut für Ur- und Frühgeschichte, Erlangen, Germany; ORCID: 0000-0003-3382-4324 [Pastoors], 0000-0002-0778-5520 [Weiß], 0000-0003-1265-061X [Uthmeier]; email: andreas.pastoors@fau.de

<sup>2</sup> Nyae Nyae Conservancy, Tsumkwe, Namibia

<sup>3</sup> Direction régionale des affaires culturelles Occitanie, Montpellier, France

**ABSTRACT** - The richness of Mesolithic footprints in the Paul Ambert gallery of Aldène cave (Hérault, France) has been known for a long time. As part of a multidisciplinary project, the footprints were studied in 2018 by indigenous ichnologists from Namibia. The results of their qualitative morpho-classificatory analyses are presented and complemented by the results of a quantitative morphometric approach. Through this set-up, the results of the two approaches add up to a more comprehensive picture of the footprints in Aldène.

According to this, a group of about 25 Mesolithic people visited Aldène once to explore the Paul Ambert gallery. The group was composed of adults, adolescents and children of both sexes. Based on the reconstructed body sizes of the adult trackmakers, they corresponded to the average body size of adult Mesolithic Europeans. The group was not close together as a unit, but split up into different small groups.

On the basis of the footprints, differences in behaviour on the way into the cave and the way out of the cave can be seen. On the way in, no member of the group carried anything additional with them. This changed on the way back, where eight adults and adolescents carried something, even though it is not possible to find out what this was exactly. Nevertheless, all evidence points at the possibility that the small children were carried on the shoulders, due to the fact – in the light of the reading of their tracks – they were in a hurry to leave the cave with considerably increased walking speed. The reason for this behaviour could be the "stop on autonomy" assumed by the analysis of the torch traces. After about 500 metres of intensive exploration of the Paul Ambert gallery, about 50 % of the torches brought along had been used up and they had to start walking back. The observation that the walking speed almost doubled on the way out testifies to the urgency of the lighting management problem that had arisen, which has obviously been solved by leaving the cave quickly.

**ZUSAMMENFASSUNG** - Der Reichtum an mesolithischen Fußabdrücken in der Paul Ambert Galerie der Höhle Aldène (Hérault, Frankreich) ist seit langem bekannt. Im Rahmen eines multidisziplinären Projekts wurden diese Fußabdrücke von indigenen Ichnologen aus Namibia im Jahr 2018 untersucht. Die Ergebnisse ihrer qualitativen morpho-klassifikatorischen Analysen werden vorgestellt und durch die Ergebnisse eines quantitativen morpho-metrischen Ansatzes ergänzt. Auf diese Weise fügen sich die Ergebnisse der beiden Ansätze zu einem vollständigeren Bild der Fußabdrücke in Aldène zusammen.

Demnach besuchte im Mesolithikum eine Gruppe von etwa 25 Personen die Paul Ambert Galerie der Höhle Aldène, um diesen Teil der Höhle zu erkunden. Die Gruppe bestand aus Erwachsenen, Jugendlichen und Kindern beiderlei Geschlechts. Nach den rekonstruierten Körpergrößen der erwachsenen Spurenmacher entsprachen diese der durchschnittlichen Körpergröße der aus dem Mesolithikum in Europa bekannten Erwachsenen. Die mesolithischen Besucher gingen nicht als geschlossene Gruppe eng beieinander, sondern sie waren in verschiedene kleine Gruppen aufgeteilt.

Anhand der Fußabdrücke lassen sich weiterhin Unterschiede im Verhalten auf dem Weg in die Höhle und auf dem Rückweg aus der Höhle erkennen. Auf dem Hinweg trug kein Mitglied der Gruppe etwas Zusätzliches bei sich. Das änderte sich auf dem Rückweg, wo acht Erwachsene und Jugendliche zusätzliche Last aufgenommen hatten. Leider ist nicht mehr festzustellen, was genau getragen wurde. Vieles deutet darauf hin, dass die kleinen Kinder auf den Schultern getragen wurden, da die Gruppe es - angesichts der Interpretation der Fußabdrücke - eilig hatte, die Höhle mit deutlich erhöhter Gehgeschwindigkeit zu verlassen. Der Grund für dieses Verhalten könnte der von der Analyse der Fackelspuren angenommene "stop on autonomy" sein. Nach etwa 500 Metern intensiver Erkundung der Paul Ambert Galerie waren etwa 50 % der mitgebrachten Fackeln aufgebraucht und der Rückweg musste angetreten werden. Die Beobachtung, dass sich die Gehgeschwindigkeit auf dem Rückweg fast verdoppelte, zeugt von der Dringlichkeit des entstandenen Problems des Lichtmanagements, das offensichtlich durch das schnelle Verlassen der Höhle gelöst wurde.

\*corresponding author

**KEYWORDS - Footprints, Mesolithic, event identification***Fußabdrücke, Mesolithikum, Identifikation von Ereignissen***Introduction**

Prehistoric humans have left clear traces of their physical presence and activities not only through their material remains, but also, under favourable conditions of preservation, in the form of imprints of their feet, hands or sometimes other body parts (Bennett & Morse 2014; Lockley et al. 2016). These imprints can be unintentional, almost casual, but they can also be deliberately produced. They document both dynamic locomotion and activities in static positions (Pastoors et al. 2021): They are snapshots of the lives of individuals and the interactions between them. The formation and preservation of imprints depends on many external factors. Of particular importance is the nature of the former surface or the walking horizon, which must be sufficiently plastic to allow an imprint to form properly. After the formation of the imprint, no erosive forces should act on the imprint in order to ensure its preservation. For the reasons mentioned above, many human imprints are found on former shore zones of lakes, in caves or even on the beach (Bennett & Reynolds 2021; Hatala et al. 2022). They exist from all periods of human evolution, all over the world. Most of the human imprints are footprints, as is the case with the traces in the Paul Ambert gallery of Aldène cave, which are the subject of this article.

In contrast to most material remains of Palaeolithic and Mesolithic hunter-gatherers, footprints are still part of everyday life, although the nature and intensity of engagement with them varies. We distinguish two general approaches to the intensive scientific study of footprints: a knowledge of footprints built up through experience and lifelong learning (Liebenberg 1990), and a knowledge generated through the application of quantitative methods of analysis (McClymont & Crompton 2021). In order to distinguish between these two methods of knowledge generation we use the terms morpho-classificatory (qualitative) and morpho-metric (quantitative) approach (Pastoors et al. 2015). In prehistoric archaeology, the morpho-classificatory approach is used to record the number of subjects, sex, age, weight, body postures, activities and gait, speed of walking, axis of locomotion, superimpositions and group configuration. Of particular importance is the deconstruction of the entire footprint record into smaller spatio-temporal sub-units (events) to which single or several subjects may belong. Complete footprints, but also parts of them, are used for identification (Robbins 1985). Furthermore, no specific reference data are required, as the characteristics applied have universal validity (Lenssen-Erz & Pastoors 2021). However, the high resolution of the results obtained by the morpho-classificatory approach is

controversial, as they cannot be falsified or verified by the morpho-metric approach (cf. Bennett & Reynolds 2021). In general, Western scientists consider the difficulty of quantifying the uncertainties of the results obtained with the morpho-classificatory approach to be problematic. This is understandable, and it would be desirable to know such values. However, determining them is not a trivial matter, as the framework conditions within a research project militate against it for a number of reasons, especially social and human aspects. In empirical tests carried out under controlled conditions, the results of the indigenous ichnologists achieved an accuracy of 98 % (Stander et al. 1997) and an inter-rater reliability of 74 % (Wong et al. 2011). Furthermore, the two main ichnologists of the present study (UK, TT) have both passed the CyberTracker tracking certification ([www.cybertracker.org](http://www.cybertracker.org)) with accuracy results of >90 % (pes. comm. Liebenberg 2018). It is against this background that the results of the identification of the footprints in Aldène are presented below - decisions taken by consensus between the three indigenous ichnologists, without any uncertainties.

While the main difficulty with the morpho-classificatory approach is the lack of a reliable method for verifying the accuracy of the results, the morpho-metric approach allows for the quantification of errors, although the number of aspects that can be recorded is limited. The number of subjects, body size, speed of walking, axis of locomotion and superimpositions can be determined based on complete footprints only (Bennett & Morse 2014; Dingwall et al. 2013; Topinard 1876). The characteristics outlined here provide reliable results even in the absence of a specific reference data set. Further details, such as sex, whose assignment based on footprints alone is a topic of ongoing debate and far from consensus in practice, can only be generated if an adequate reference data set is available (Kanchan et al. 2014).

Previously, prehistoric footprints were investigated using either one or the other method. This is the first time that both approaches have been applied to a single site with prehistoric footprints. The aim is to generate as much knowledge as possible about the events at the Paul Ambert gallery of Aldène cave in France by the multi-method approach. The present article examines traces that document the locomotion in space and the interaction between humans and the natural cave environment. But it is the intention to go beyond the reconstruction of the activities of each subject. The focus is on the identification of episodes of the individual subjects as well as the entire group that visited the Paul Ambert gallery of Aldène cave.

The study of the human footprints of the Paul Ambert gallery in Aldène cave has never really been

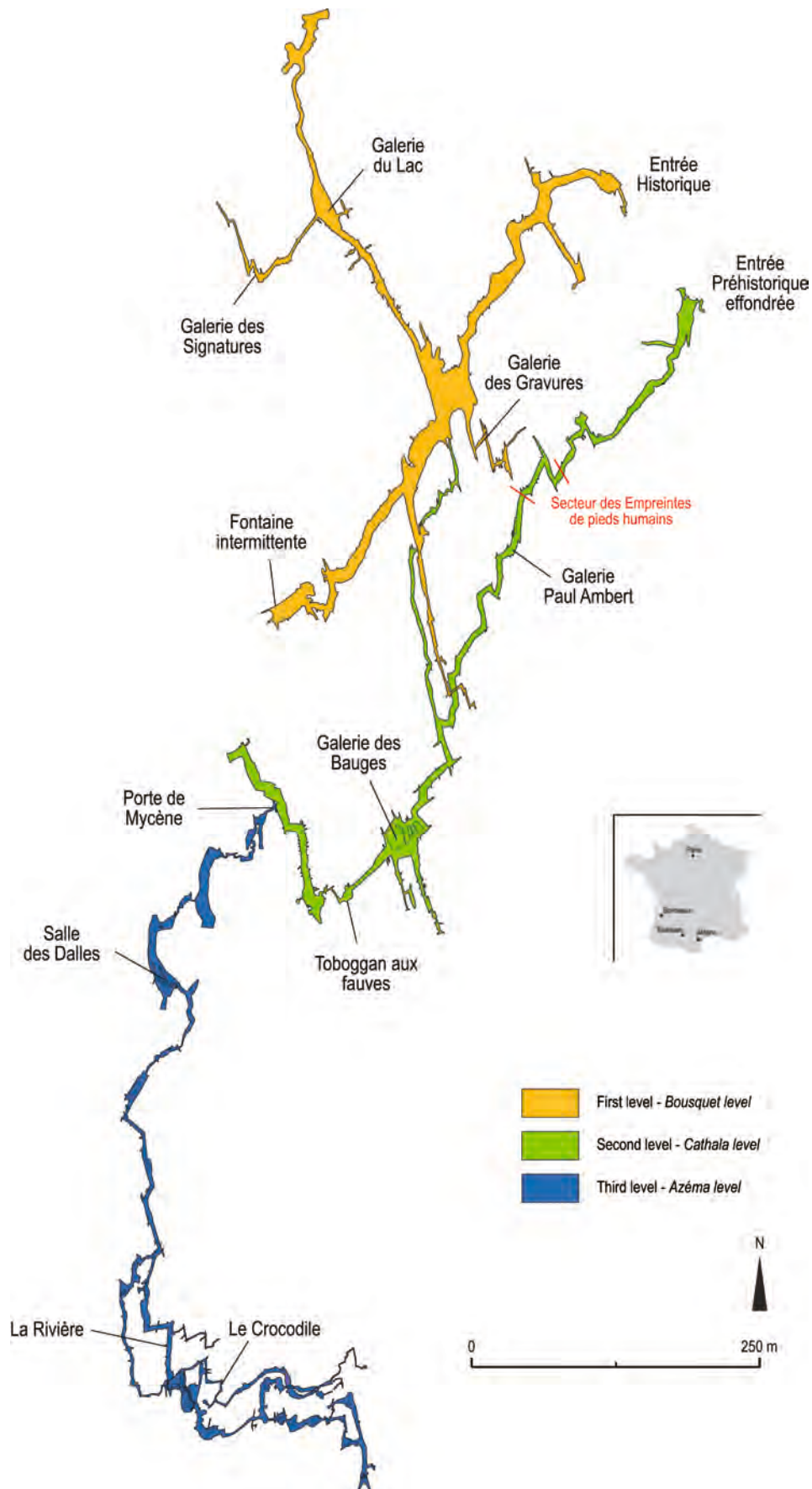
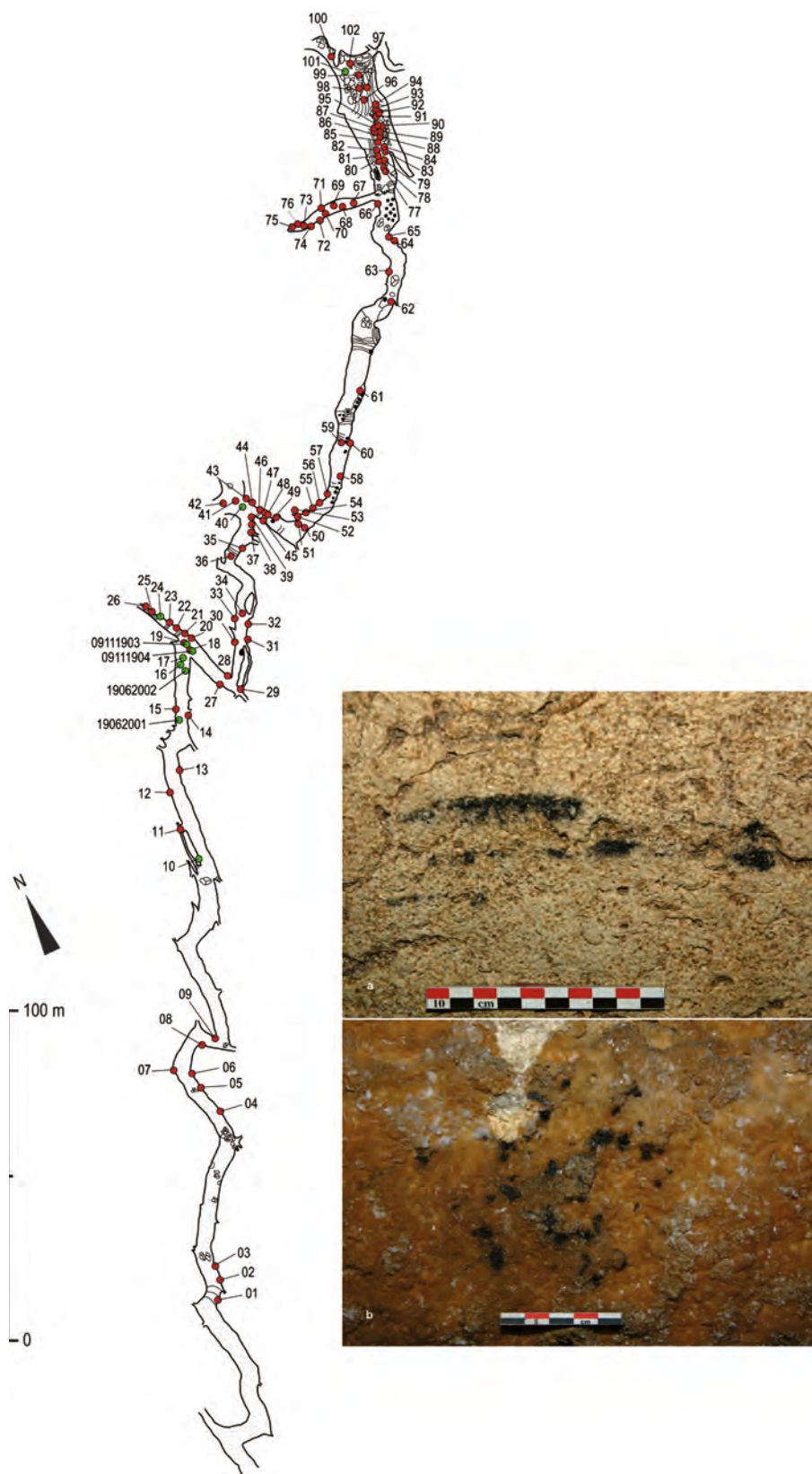

Fig. 1. Topographical plan of the first three levels of Aldène cave and the location of the main galleries (French Federation of Speleology – Technical UV instructor 1998).

Abb. 1. Topographischer Plan der ersten drei Ebenen der Höhle von Aldène und Lage ihrer Hauptgänge (Französischer Höhlenforscherverband - Technical UV instructor 1998).



**Fig. 2.** Aldène. Distribution plan of different traces of torches (red dot not dated, green dot AMS <sup>14</sup>C dated) found in the area explored by prehistoric visitors. (a) Unintentional trace of a torch corresponding to a lateral friction of the lighting device. This type of vestige makes it possible to accurately reproduce the Mesolithic path within the gallery; (b) intentional trace of a torch, marked by an impact perpendicular to the wall.

**Abb. 2.** Aldène. Verteilungsplan der verschiedenen Fackelspuren (roter Punkt nicht datiert, grüner Punkt AMS <sup>14</sup>C datiert), die von prähistorischen Höhlengängern in den von ihnen erkundeten Teilen der Höhle hinterlassen wurden. (a) Unbeabsichtigte Fackelspur, entsteht durch die seitliche Berührung der Lichtquelle an der Wand. Diese Art von Spur ermöglicht eine genaue Rekonstruktion des mesolithischen Wegenetzes innerhalb der Höhle; (b) absichtliche Fackelspur, entsteht durch einen vertikalen Impuls der Lichtquelle an der Wand.

Ech-N° Ambert et al. 2007	Torch-N° Galant 2007	Torch-N° Galant 2017/2021	N° 2022	Lab-N°	calBP	<sup>14</sup> C AMS BP	Reference	Species, note
19	17	35	-	MC-492	9,485-8,771	8,200 ± 130	Ambert et al. 2000	Cornifères (genévrier)
20	40	34	-	Beta 132629	9,265-8,647	8,070 ± 80		
21	10	41	-	Beta 120332	8,988-8,602	7,930 ± 60		
22	16	35	-	Beta 120333	8,986-8,591	7,900 ± 60		
23	101	-	-	Beta 145173	8,770-8,476	7,830 ± 40	Ambert et al. 2007	
24	24	31	-	Beta 120334	8,763-8,416	7,790 ± 60	Ambert et al. 2000	
-	-	-	19062001	Lyon 18203	9,539-9,444	8,485 ± 40	unpublished	Sample too small, undetermined
-	-	-	19062002	Lyon 18204	8,985-8,645	7,950 ± 35		
-	-	-	09111904	Lyon 18205	8,981-8,592	7,895 ± 40		
-	-	-	09111903	Lyon 18201	10,177-9,776	8,870 ± 40		

**Tab. 1.** Aldène. Direct AMS <sup>14</sup>C dating of the torch marks in the Paul Ambert gallery. The data were calibrated using OxCal-Online relying on the IntCal20 curve (Reimer et al. 2020) and reported with a probability of 95.4%.

**Tab. 1.** Aldène. Direkte AMS <sup>14</sup>C-Datierung von Fackelspuren in der Paul Ambert Galerie. Die Daten wurden mit OxCal-Online anhand der IntCal20-Kurve (Reimer et al. 2020) kalibriert und mit einer Wahrscheinlichkeit von 95,4% angegeben.

carried out since the site was discovered in 1948. Faced with this lack, a comprehensive research project including 3D documentation, photogrammetry, inventory of biometric and paleoanthropological aspects, and ichnology of all human footprints has been carried out since 2017 (Galant et al. 2021). The results presented below are an integral part of the ongoing overall investigations in Aldène cave.

## Materials

Aldène cave (Fig. 1) is located in southern France, in the centre of the Minervois plateau. The Minervois plateau is situated at the foot of the Montagne Noire and overlooks the vast Languedoc coastal plain, which extends to the Mediterranean Sea. The cave opens to the gorge of the Cesse, a river that rises in the foothills of the Montagne Noire and flows south to join the Aude river. As it crosses the limestone plateau of the Causses de Minerve, it cuts deep gorges that revealed the entrance to Aldène.

According to the current state of knowledge, the cave is developed over more than 9 km of galleries which are spread over four different hydrogeological levels (Fig. 1). The first two levels, of which the first (Bousquet level) has always been known and the second (Cathala level) was discovered in 1948, are inactive vadose systems. The third level (Azéma level), discovered in 1992, has a temporary water flow during flood periods, while the fourth level, discovered in 1994, constitutes part of the permanent subterranean course of the Cesse (Galant et al. 2021).

## Archaeological context

Apart from human footprints, human presence in the Paul Ambert gallery is also evidenced by the occurrence of charcoal traces on the walls. After their discovery in 1948, these remains were interpreted as torch smears and about thirty of these traces had been catalogued.

The completion of a new systematic inventory based on a detailed examination of the floors and walls led to the identification of 102 points related to lighting management during a Mesolithic visit (Galant et al. 2007). Ten of these traces were dated with the AMS <sup>14</sup>C method. The majority of the dates falls into the timespan between 9,000 and 8,500 calBP and validates the assertion to the Mesolithic. The distribution of the charcoal traces on the cave walls, combined with the results of the analysis of the human tracks described below, suggest the singularity of this event of cave exploration by humans (Ambert et al. 2000; Ambert et al. 2007) (Tab. 1). The range of the radiocarbon dates is best explained by sample size and possible contamination.

Traces of torches are present immediately from the today collapsed entrance, whose natural obstruction was already well advanced during the time of the prehistoric exploration (Guendon et al. 2004), until about 500 m into the cave (Fig. 2). Experiments on the functionality of torches (Galant et al. 2007) have revealed that this corresponds well to the lighting of the torches with bundles of the thin parts of fire sticks which burn down very fast. The traces found on the walls throughout the rest of the subterranean path could be divided into two different types (Fig. 2): (1) accidental traces corresponding to unintentional impacts of the lighting systems under particular conditions related to the morphology of the cave network and advance through the cave; (2) intentional traces, always preceded by impacts on the wall to break the longest, already burnt ends of the torches and thus make a mark during the visit. Accidental traces generally correspond to the lateral friction of the torches, leaving very characteristic marks on the walls. This distinguishes them from the intentional traces which were produced by crushing the end of the torch perpendicular to the wall.

More than 500 m from the Mesolithic entrance, a last intentional trace of a torch on the wall seems to indicate

the end point of the Mesolithic visit to the cave. At this point in the cave, there is no immediately obvious reason for this feature because the gallery still extends over vast stretches and a great distance: no natural obstacle hinders the progression at this level. Detailed examination of the walls beyond this passage revealed no trace of a torch; similarly, no charcoal remains or human footprints were seen on the floor. The examination of the geomorphological conditions of this part of the cave network suggests that there is no reason for differential conservation of these types of remains. Since it is unlikely that the Mesolithic visitors would have left no more traces from this point onwards if they had moved on, it can be assumed that this last trace of a torch corresponds to the end of the Mesolithic visit. The most probable hypothesis for this decision is called in speleology "a stop on autonomy" (Galant et al. 2007). Indeed, it seems obvious that to embark on this exploration, visitors had to bring a certain number of torches necessary for the production of light. It is therefore easy to imagine that at this point, if they had consumed about half of their reserve, they would have decided to return, as light was crucial, even vital, for this kind of expedition. Therefore, this U-turn could be seen as a very ancient testimony in the context of a Mesolithic speleological exploration that has the same behavioural characteristics as those of today's speleologists (Galant et al. 2007).

The torch marks on the walls and floor of the main gallery and the side passages testify to a total walking distance of over 1,000 m (Galant et al. 2007: 37–38). According to the results of the investigations into the progress of Mesolithic cave exploration, the side passages were visited on the way in. Apart from the exploration of a fissure not visible on the way in, the return was directly to the Mesolithic entrance without any further detours (Galant et al. 2007: 75).

Further torch marks on the first floor, the Bousquet level, testify more Mesolithic explorations of caves in the immediate vicinity (Ambert et al. 2007).

### Human tracks

Human tracks, discovered in May 1948 by Abbé Dominique Cathala (Ambert et al. 2007), are distributed in a very limited part of the total space of the cave inspected by the Mesolithic human group (Fig. 3). It is estimated that only about 10% of the path is still partially marked by human footprints. In the particular case of Aldène it can be estimated that 40 to 50% of the substrate of the Mesolithic paths could be appropriate for leaving tracks, as the floor of the cave is heterogeneously covered with limestone blocks, sinter and clay. This situation suggests that many traces may have disappeared. This disappearance is mainly due to three reasons: (1) there is a lateral inflow of water into the gallery, which has partially cut through the clay filling superficially; (2) the same inflow of water and other flow sources have generated a partial hydrological loading of the galleries, a phenomenon that has resulted in a

surface inflow of clay-silt that has partially covered the clay floors; (3) the use of the cave network since its discovery in 1948 has resulted in extensive trampling of areas that may have borne human footprints. It must also be assumed that in a very specific way other taphonomic phenomena have altered the conservation of footprints (falling water drops from the vault, falling blocks, calcifications on the floor, etc.).

These preservation conditions explain why the human footprints are concentrated at several points over only about 50 m (Fig. 3). In this area, five sectors can be identified that show human footprints. These sectors are sequenced according to the current access to the gallery, i.e., by moving from the inside of the cave network to the Mesolithic entrance, which is currently blocked.

- Sector A: This is the last complex discovered and the southernmost with footprints. They develop over a 4.4 m long space with an average width of 1.1 m at the base near to the wall. In this area, the original floors have been preserved despite modern circulation since the discovery Sector A consists of a nine-footprint trackway on the east side of the gallery, as well as an isolated footprint. On the other side of the gallery, to the west, there is another probable footprint.
- Sector B: This represents a small set of poorly identified footprints in a now dry and partially hardened, formerly liquid clay puddle, covering an area of 2 x 2.7 m. We assume that several tracks are present but remain very difficult to identify. This sector is just before the start of the main path into the interior of the cave.
- Sector C: This is the area with the majority of human footprints. They are found along the entire sector of the gallery oriented on a southwest-northeast axis. It covers an area of about 3 m wide and about 30 m long. Abbé Dominique Cathala had found almost 200 human footprints on its surface, but due to superimpositions recognized in the course of later surveys, it is ascertained that this number is much higher. Léon Pales has identified more than 300 footprints and current counts estimate 400 footprints (Galant 2017). However, this surface shows several areas without footprints. Because these are positioned in between footprints that allow to reconstruct a continuous walking activity, they must go back to taphonomic reasons like erosive processes in the cave. The entire northern part of this path is partially covered by a stalagmitic floor that has also sealed human footprints which remain difficult to identify.
- Sector D: It is located on the same axis as the previous sector and only less than one metre from its northeastern end. It is a formerly dry sinter basin that was crossed by some of the Mesolithic visitors. This area, measuring approximately 1.3 x 2.4 m, contains at least 14 human footprints; they have the particularity of being accompanied by two traces of

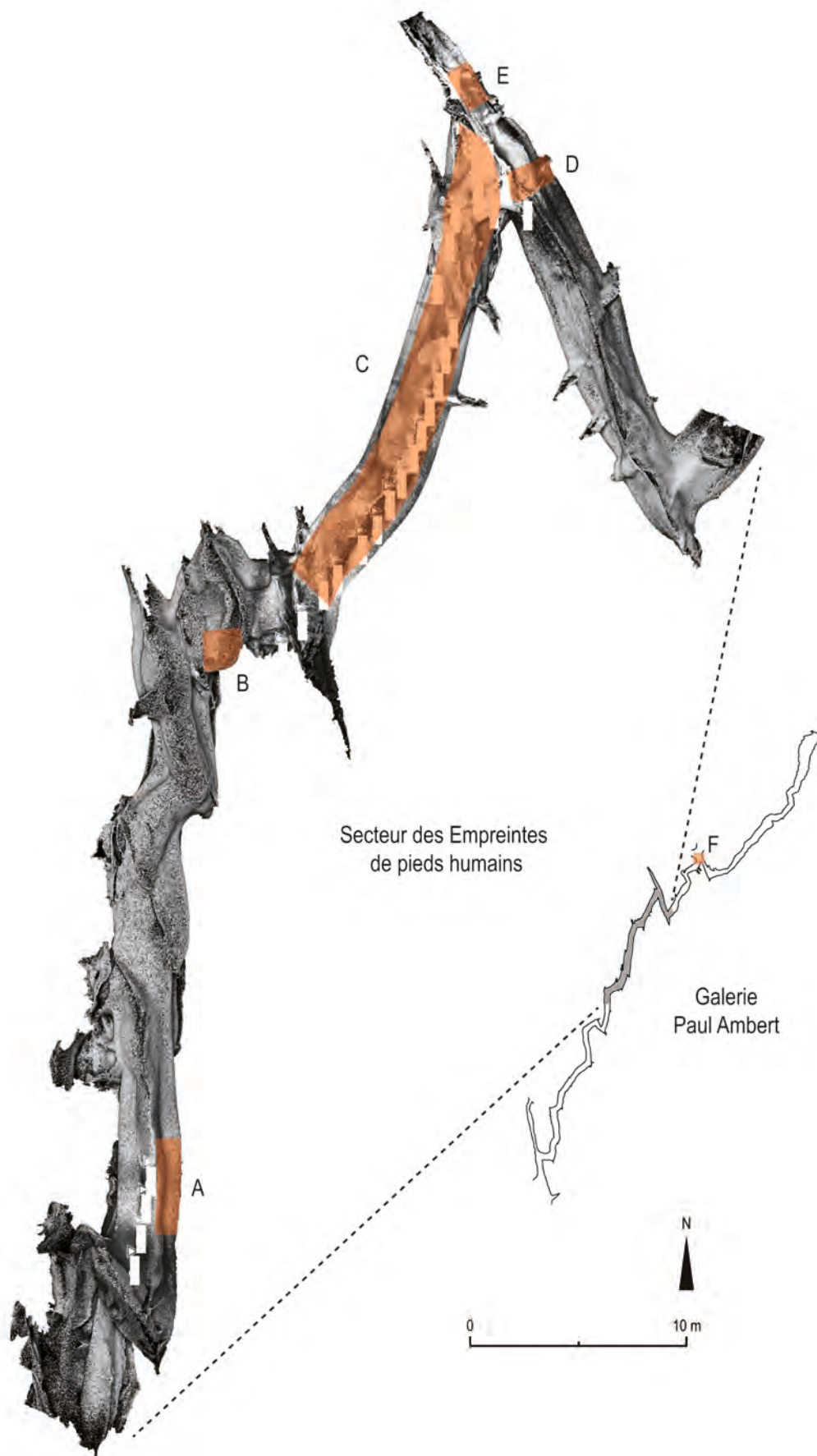

Fig. 3. Aldène. Distribution plan of sectors A-F with human footprints (Orthophoto: IUT Nîmes/Géomesure, Infographic: Philippe Galant).  
 Abb. 3. Aldène. Verteilungsplan der Sektoren A-F mit menschlichen Fußabdrücken (Orthofoto: IUT Nîmes/Géomesure, Infografik: Philippe Galant).

sticks dragged into the clay of the cave floor. The imprints of the ends of the sticks are in direct relation to the footprints.

- Sector E: This is the start of the gallery that opens in front of the previous sector to the left and northern end of sector C. It seems that the group of Mesolithic visitors entered this gallery, at the highest level of its vault, through an elongated sinter basin filled with fairly liquid clay. The floor is now totally calcified, and thus preserved the footprints. Many footprints are visible, more than fifty of them, in a space very constrained by the morphology of the passage which forms a surface of 1.5 x 2.8 m.
- Sector F: This footprint sector is the most remote in the network. It does not have a human footprint as such. The passage between the two ancient lakes shows a ceiling height of about 0.6 to 0.8 m. Bear paw prints, a human handprint and traces that may correspond to human knees are locally restricted in an area of about ten square metres.

## Methods

As part of the extensive research project in Aldène, which started in 2017 and is still ongoing, three Namibian indigenous ichnologists (TC, /UK, TT) were engaged who have already worked in the Tracking in Caves project (Lenssen-Erz et al. 2018; Pastoors et al. 2017; Pastoors et al. 2015; Pastoors et al. 2021). Normally, they work as professional trackers for commercial hunting and, especially, as economic support for their families and villages through traditional hunting practices. Three concentrations of human tracks in the Paul Ambert gallery of Aldène Cave were selected in the following locations: Sector A, C and D (Fig. 3). There, the three ichnologists were asked to investigate the discernible footprints and other traces, while the accompanying archaeologists (AP, TLE) were assigned to document their analysis. The research in Aldène took place from 2<sup>nd</sup> to 8<sup>th</sup> October 2018.

### Laser scan model

3D models of the relevant sectors with the footprints were generated using laser scanners (3D Faro focus 120 MS and 3D Faro focus S 150) with an accuracy of less than one millimetre. Orthophoto plans were then generated from the 3D data, with greyscale corresponding to the intensity response of the scanner (Galant 2017).

### Photogrammetric model

Photogrammetric models were generated by Thierry Montesinos (Association Spéléologique Nîmoise) based on the Structure from Motion method (Galant 2017). The necessary photos were taken with a Canon EOS 7D (CMOS sensor with APS-C sensor size) with a Canon EF S wide-angle zoom lens 10 mm-22 mm F/3.5-4.5, with the focal length fixed at 22 mm. For the largest sector C, 2,200 photos had to be taken to get an aerial coverage

of the entire footprints. The software used to generate the models was Agisoft PhotoScan Professional Edition, v.1.4.

### Morpho-classificatory approach: Reading footprints

Reading footprints is based on the identification of traces left behind by humans according to the principle of the pre-iconographic description by Panofsky (Lenssen-Erz & Pastoors 2021; Pastoors & Lenssen-Erz 2020). Traces are identified, put in relation to each other and summarized as events. Practical experience (familiarity with objects and phenomena) is an absolute prerequisite for a successful application of the pre-iconographic description, from which a positive correlation between experience and descriptive accuracy can be derived (Lenssen-Erz & Pastoors 2021). In the case that the spectrum of personal experience is not sufficient, this spectrum must be extended by consulting publications or experts. Practical experience, in turn, helps to determine which publication or expert is to be consulted (Panofsky 1962: 9).

A standardised process of recording the workflow of the indigenous ichnologists in reading prehistoric human tracks has been developed in the course of the Tracking in Caves project. First of all, lists were compiled with information on each individual footprint examined. The following aspects were documented:

- Subject number: The subject number identifies each individual (trackmaker) independently of the study area. This makes it easy to follow each subject through the cave.
- Track number: The track number designates each individual human trace examined and listed in the project. Subject and track number together form a distinctive unit. They are continuous and thus allow an unambiguous assignment of the human traces in each part of the cave.
- Age: The results of the morpho-classificatory analysis of age are given very precisely by the indigenous ichnologists. In consideration of the fact that such a precise age estimation by means of footprints depends on the respective reference collection and/or personal experience, the data of the indigenous ichnologists are grouped together in age classes according to Martin (Martin 1928) – neonatus, infans I (0.5-6 years), infans II (7-13 years), juvenis (14-20 years), adultus (21-40 years), maturus (41-60 years) and senilis (>60 years).
- Sex: If the sex of the subject can be identified, it is recorded as female or male.
- Physique: This aspect provides information about the shape of the body. This is rather a matter of deviations from a normal physique than a precise definition of a certain shape.
- Handicap: Under handicap, observations are recorded that relate to deviations from a well-balanced human being. No statements are made about the medical causes.
- Track type: Track type specifies the exact body part



that generated the traces. This includes foot, hand, knee, elbow and others (e.g., not extended body parts like tools, sticks).

- Side: If the side of the body part can be identified, it is recorded as left or right.
- Additional weight: The additional weight refers to the characteristics of tracks when movements of a subject deviate from the normal gait or depth of imprint.
- Gait: Under this point, statements are made about the manner of the executed locomotion. This includes safety and speed, as well as movement in a group or alone.
- Direction: The direction of movement is documented in cardinal direction. Specific local information is given for better orientation in the cave.
- Trackway: Here it is noted whether the footprint is part of a series of footprints of the same subject, or whether it is isolated. Each trackway gets a different number.
- Event identification: Summary of traces of individual or several subjects in temporal, spatial and content-related connection with each other.
- Taphonomy: This aspect refers to the state of preservation of the various traces which can be influenced by both natural and anthropogenic factors.
- Substrate: The substrate refers to the sediment or ground in which the track was formed.
- Reliability of identification: Particularly important for the comprehensibility of the analysis is the judgement of its reliability on the basis of preservation and visibility. For this purpose, a subjective five-stage classification was applied by the indigenous ichnologists ranging from very good (1) to unsatisfactory (5). The intermediate stages are good (2), satisfactory (3) and sufficient (4); this allows to eliminate dubious identifications from analytical processes.
- Remarks: An open field for comments of any kind.

The position of every track was located on scaled photographic plans. All work sequences were recorded as video. In this way, not only can the results be checked and compared with each other, but also further linguistic research can be carried out. At the end stands a database (catalogue) containing the results of the morpho-classificatory analysis and event identification, which can easily be extended with morpho-metric parameters of the footprints.

The arguments of the indigenous ichnologists about how a combination of footprints is identified as a track, and how several tracks are sometimes interpreted as a coherent event, point in the direction of perception psychology and Gestalt principles in particular. By Gestalt is meant "a unitary whole of varying degrees of detail, which, by virtue of its intrinsic articulation and structure, possesses coherence and consolidation and thus detaches itself as a closed unit from the surrounding field"

(Maynard 2005: 501 citing Gurwitsch 1964).

The concept of Gestalt was introduced by Max Wertheimer (Wertheimer 1923). Since then, research into Gestalt formation focused on the perception and interpretation of grouped objects as well as on small entities within larger environments. The concept of Gestalt is of relevance still today (Wagemans et al. 2012a; Wagemans et al. 2012b). So-called Gestalt laws (Fitzek & Salber 1996) or principles are particularly vital in the advertisement industry (e.g. Graham 2008) and, besides psychology (e.g. Wörgötter et al. 2004), they have also received quite some attention in computer science and mathematical approaches (e.g. Elder & Goldberg 2002; Wen et al. 2010; Zhu 1999). Some of the Gestalt principles are: Figure-ground articulation, proximity, common fate, similarity, continuity, closure, past experience and good Gestalt (Todorovic 2008). All these principles are at work in perception when regarding tracks, single or in trails, and making sense of their complex and combining information.

### **Morpho-metric approach: morphological landmarks and footprint data acquisition**

All dimensional and morphological parameters from the footprints identified by the morpho-classificatory approach were compiled using laser scan and photogrammetric models. The accuracy of the resulting models, measured using Adobe Photoshop CS5, is 1 mm (SI1).

The measurements were based on selected landmarks proposed by Robbins (Robbins 1985, 61-62, Fig. 5.1, Tab. 5.1). (Fig. 4). This includes seven morphological landmarks: first digit (D1), second digit (D2), medial metatarsal (mt.m), lateral metatarsal (mt.l), medial calcaneal concavity (cc.m), lateral calcaneal tubercle (ctu.l) and Pternion (pte). Four distances were measured between these seven points: foot length (FL) between Pternion and the first digit (FL\*D1) as well as the second digit (FL\*D2), foot width (FW) between medial metatarsal and lateral metatarsal (mt.m-mt.l), and foot heel width (FHW) between medial calcaneal concavity and lateral calcaneal tubercle (cc.m-ctu.l). For the maximal foot length (max. FL), the distance between Pternion-D1 was used.

To analyse the metric footprint variability, we use Principal Component Analysis (PCA) (Hotelling 1933) on the above-mentioned measurements. Here we had to select the best-preserved human footprints where all aforementioned four measurements could be recorded. The PCA results are coloured so that each colour corresponds to a subject identified by the morpho-classificatory approach. PCA is a linear eigenvector analysis method for dimension reduction of multivariate data sets. It finds directions in the form of components with 'loadings' of the individual variables (here measurement distances) that maximise the variance of the data set. One advantage of PCA is the direct representation of the influences of the individual variables on the principal components. In other words,

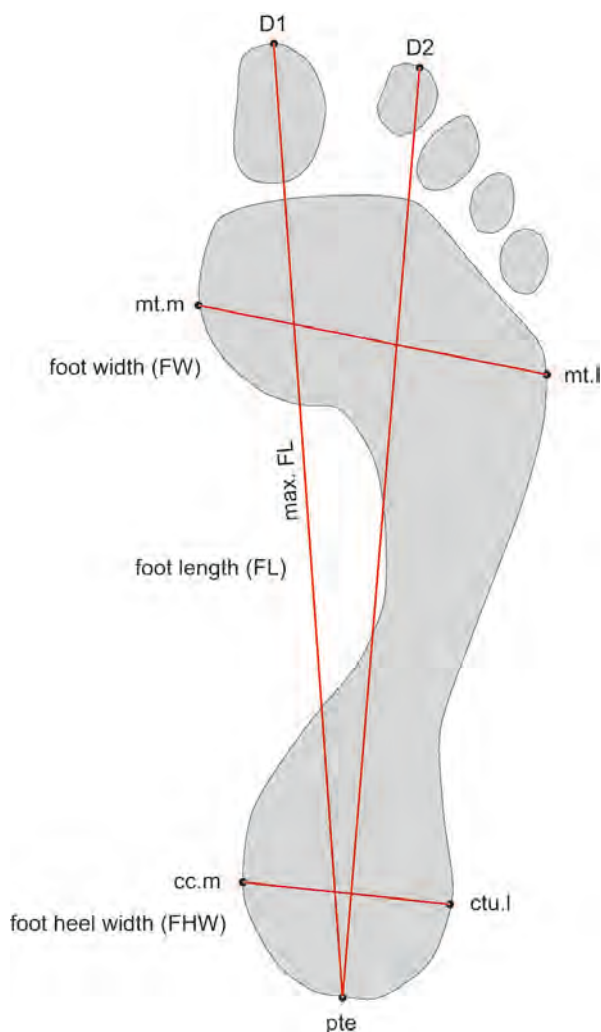

**Fig. 4.** Morphological parameters used in the current study (Robbins 1985): first digit (D1), second digit (D2), medial metatarsal (mt.m), lateral metatarsal (mt.l), medial calcaneal concavity (cc.m), lateral calcaneal tubercle (ctu.l) and Pternion (pte); foot length (FL) between Pternion and the first digit (FL\*D1) as well as the second digit (FL\*D2), foot width (FW) between medial metatarsal and lateral metatarsal (mt.m-mt.l), and foot heel width (FHW) between medial calcaneal concavity and lateral calcaneal tubercle (cc.m-ctu.l). For the maximal foot length (max. FL), the distance Pternion-D1 was used.

**Abb. 4.** Morphologische Parameter, die in der vorliegenden Studie verwendet wurden (Robbins 1985): erste Zehe (D1), zweite Zehe (D2), medialer Mittelfußknochen (mt.m), lateraler Mittelfußknochen (mt.l), mediale Konkavität des Fersenbeins (cc.m), lateraler Fersenbeinhöcker (ctu.l) und Pternion (pte); Fußlänge (FL) zwischen Pternion und erster Zehe (FL\*D1) sowie zweiter Zehe (FL\*D2), Fußbreite (FW) zwischen medialem Mittelfußknochen und lateralem Mittelfußknochen (mt.m-mt.l) und Fersenbreite (FHW) zwischen medialer Konkavität des Fersenbeins und lateralem Fersenbeinhöcker (cc.m-ctu.l). Für die maximale Fußlänge (max. FL) wurde der Abstand Pternion-D1 verwendet.

the relationships between the individual variables and the position of each footprint as well as the footprints to each other can be derived directly from the result diagram of the eigenvectors. This can serve as a basis for further discussion, as a visualisation of relationships between footprints facilitates an interpretation of the identity and number of trackmakers from Aldène away from the raw data. Furthermore, PCA makes no assump-

tions of groups prior to the analysis. Data management as well as the statistical analyses were done in the open-source statistic software R, v.4.2.1 (R Core Team 2022). The PCA was calculated using the packages 'FactoMineR' (Le et al. 2008) and 'factoextra' (Kassambara & Mundt 2020). To ensure that all variables have the same influence on the result, the PCA is based on a correlation matrix in which all variables are transformed into correlation coefficients (mean 0, unit deviation 1).

As an additional means of data analysis to compare metric measurements with the observations made by the indigenous ichnologists and to complement the patterns resulting from PCA, we applied hierarchical clustering to the four measurements (see above). We used the *hclust* algorithm of the R base package as well as the libraries *dendextend* (Galili 2015) and *ggdendro* (Vries & Ripley 2022). We applied Ward's method, as this minimizes variation within and maximizes variation between clusters (Matzig et al. 2021; Ward 1963).

Aware that sex assignment based on footprints alone is controversial in research and far from consensus in practice, the method proposed by Kanchan et al. based on footprint dimensions - FW and foot heel width (FHW) - was applied (Kanchan et al. 2014).

According to Krishan et al. (2015) the max. FL is the most reliable metrics for predicting body size (Krishan et al. 2015), as it represents 15% of the height of the trackmaker (Bennett & Morse 2014; Kanchan et al. 2008; Topinard 1876).

For the walking speed estimation, the established method of Dingwall et al. (2013), based on the research on the empirical relationship between stride length (SL) and speed (Alexander 1984), was used:  $Speed\ m/s = -1.39 + 0.48 * (SL / meanFL)$ .

## Results

The results are presented with an indication of the method by which the results were obtained – morpho-classificatory or morpho-metric approach (SI1). If results are available from both, those of the morpho-classificatory are presented first and then those of the morpho-metric approach.

### Track-type, side and trackways

**Morpho-classificatory approach:** Out of more than 400 footprints, 156 footprints and the two traces of a stick (S25-1 to S25-5, E25; S25-6 and S25-7, E26) could be identified more closely. The remaining ones are not integrated in this analysis for various reasons (out of reach, poor conservation, insufficient lighting, etc.). Only footprints are among them. Knees, buttocks, hands or tracks of other body parts are completely missing. All footprints are from barefoot subjects - 77 left and 79 right.

Most of the 156 footprints belong to connected trackways (136 footprints), of which 37 have been determined. Trackways consist of between two and nine footprints, with a mean of 3.7 footprints per trackway.



**Fig. 5.** Aldène, sector C: Projection of the footprints identified by the morpho-classificatory approach onto the orthophoto, as well as the events E1, E7, E18, E20, E28, E37 and superimpositions S13-10/S19-1 detailed in the text (grey scaled orthophoto based on 3D laser scan model, Orthophoto: IUT Nîmes/Géomesure, Infographic: Andreas Pastoors). Scale 5 m.

**Abb. 5.** Aldène, Sektor C: Projektion der mittels morpho-klassifikatorischem Ansatz identifizierten Fußabdrücke auf das Orthofoto, ebenso wie der im Text beschriebenen Ereignisse E1, E7, E18, E20, E28, E37 und der Überlagerungen S13-10/S19-1 (grau skaliertes Orthofoto basierend auf 3D-Laserscanmodell, Orthofoto: IUT Nîmes/Géomesure, Infografik: Andreas Pastoors). Maßstab 5 m.

Subject	Morpho-classificatory approach			Morpho-metric approach		Total (N)	PCA (N)	PCA (%)
	Sex	Age class*	Physique	Mean FL (mm)	Body size (cm)**			
S1	male	juvenis	normal	215.1	143.4	16	10	62.5
S2	male	adultus	nts	253	168.7	1	1	100
S3	male	maturus	normal	240	160.0	13	9	69.2
S4	female	adultus	tall	235.6	157.1	8	5	62.5
S5	male	infans II	small	130	86.7	1	-	-
S6	female	infans I	small	126	84.0	1	-	-
S7	male	adultus	strong	230.4	153.6	12	11	91.7
S8	female	juvenis	normal	216	144.0	16	13	81.3
S9	male	adultus	normal	228.2	152.1	11	10	90.9
S10	female	infans II	normal	188	125.3	2	2	100
S11	female	maturus	normal	232.7	155.1	9	9	100
S12	female	adultus	strong	231.3	154.2	5	3	60
S13	male	infans I	normal	150	100.0	13	10	76.9
S14	female	adultus	normal	233.3	155.5	9	8	88.9
S15	female	juvenis	normal	229.8	153.2	9	6	66.7
S16	male	infans II	normal	195.5	130.3	5	4	80
S17	male	adultus	normal	228	152.0	1	1	100
S18	male	maturus	normal	241	160.7	2	-	-
S19	male	adultus	normal	244	162.7	2	1	50
S20	female	juvenis	light	195.6	130.4	6	5	83.3
S21	female	infans I	small	124	82.7	1	1	100
S22	male	juvenis	normal	209	139.3	2	2	100
S23	male	adultus	normal	240	160.0	2	2	100
S24	male	infans I	normal	156	104.0	1	1	100
S25	male	infans II-juvenis	normal	203.5	135.7	7	4	57.1
S26	nts	infans I	normal	-	-	1	-	-
Total						156	118	75.6

**Tab. 2.** Aldène. Identity of the trackmakers. Main results of the morpho-classificatory and the morpho-metric approaches - \*Martin 1928 - neonatus, infans I (0.5-6 years), infans II (7-13 years), juvenis (14-20 years), adultus (21-40 years), maturus (41-60 years) and senilis (>60 years); \*\*Topinard 1876 (15 %); nts = nothing to say.

**Tab. 2.** Aldène. Die Identität der Subjekte, die Fußabdrücke hinterlassen haben. Ergebnisse des morpho-klassifikatorischen und des morpho-metrischen Ansatzes - \*Martin 1928 - neonatus, infans I (0,5-6 Jahre), infans II (7-13 Jahre), juvenis (14-20 Jahre), adultus (21-40 Jahre), maturus (41-60 Jahre) und senilis (>60 Jahre); \*\*Topinard 1876 (15 %); nts = nichts zu sagen.

**Number of subjects**

*Morpho-classificatory approach:* The 156 footprints originate from 26 subjects, whose individual features as deduced from the analysis of their footprints will be described in more detail below (Fig. 5, Tab. 2).

*Morpho-metric approach:* To complement the results obtained by the morpho-classificatory approach, the individual records of the dimensional and morphological parameters from the footprints are coloured so that each colour corresponds to a subject identified by the morpho-classificatory approach. In the result of Principal Component PC1 plotted against Principal Component PC2 (Fig. 6), the footprints of 15 of the total 26 subjects are plotted in small clusters - S1, S3, S4, S7, S8, S10, S11, S12, S13, S14, S15, S16, S20, S22 and S25. Unfortunately, there is not enough data available from the other subjects. Thus, a total of 76 % of the footprints identified are included in the PCA, varying between 50 % and 100 % for the individual subjects. Overall, it appears that each individual subject is represented by its dimensional and morphological

parameters from the footprints in the PCA (FL\*D1, FL\*D2, FW and FHW). It also becomes clear that the dimensions of the footprints of a subject vary. This variability is influenced by various parameters: change of substrate, change of substrate specifications, change of walking speed and/or the additional weight carried play a central role. Overlaps between footprints of the individual subjects also become clear. This is not surprising given the many footprints of similar dimensions.

On closer inspection, the sorting by PCA on PC1 reflects age separately by sex, identified using morpho-classificatory approach. Young male subjects (infans and juvenis) are found in the range with negative values, older subjects (adults and maturus) in the range with positive values. For female subjects, this distribution is similar in principle, but slightly shifted into the range of positive values, so that juvenile subjects are grouped around the 0-line. In contrast, the sorting on PC2 shows no obvious pattern. FHW does not seem to play a major role in differentiating sex and

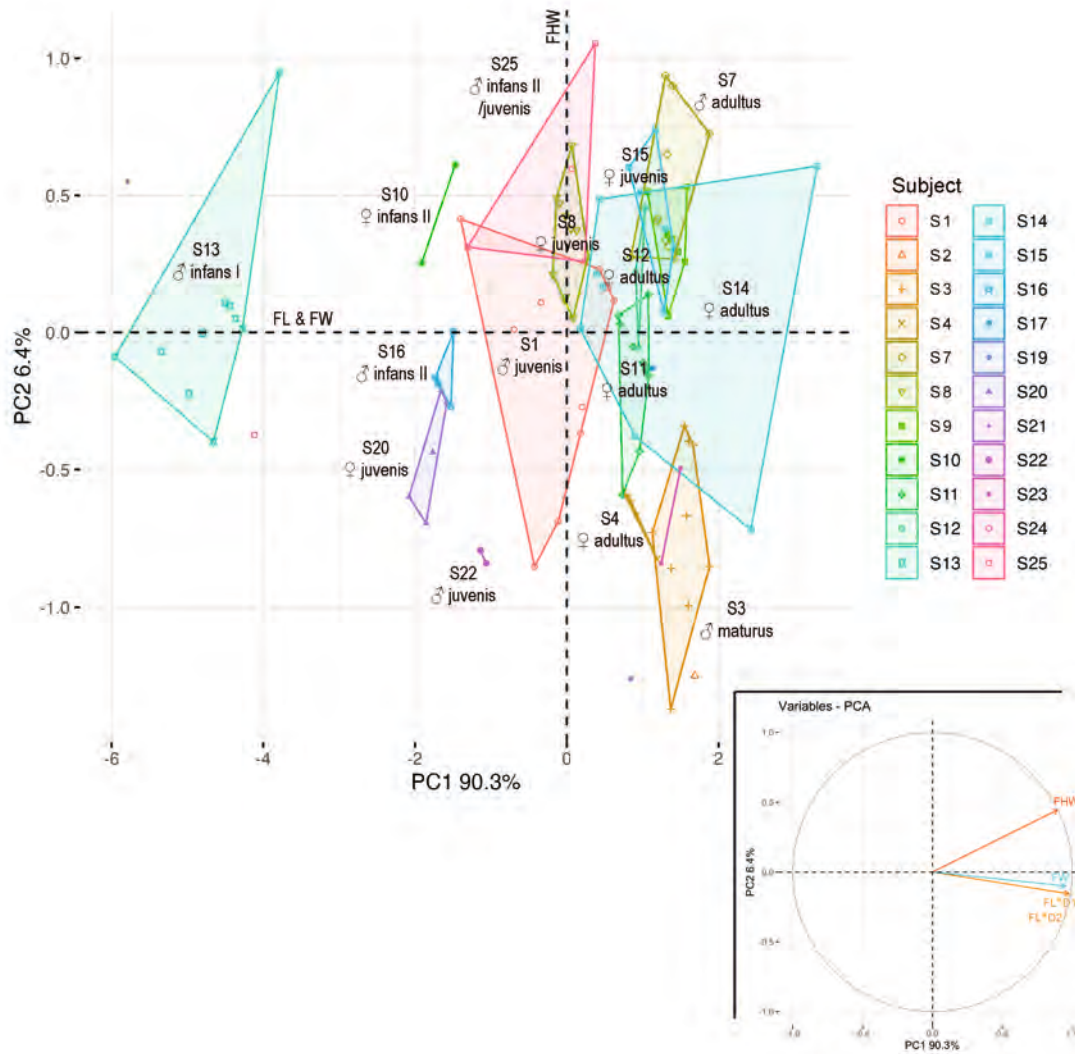

**Fig. 6.** Aldène. Principal Component Analysis (PCA) of the metric variability of all footprints where all measurements (FL\*D1, FL\*D2, FW and FHW) could be recorded. The PCA results are coloured so that each colour corresponds to a subject identified by the morpho-classificatory approach. Below, the representation of the influence of the measured distances on the result of the PCA.

**Abb. 6.** Aldène. Hauptkomponentenanalyse (PCA) der metrischen Variabilität aller Fußabdrücke, für die alle Messwerte (FL\*D1, FL\*D2, FW und FHW) erfasst werden konnten. Die Ergebnisse der PCA sind farbig dargestellt, wobei jede Farbe einem Subjekt entspricht, das durch den morpho-klassifikatorischen Ansatz identifiziert wurde. Nachstehend ist der Einfluss der gemessenen Distanzen auf das Ergebnis der PCA dargestellt.

age, or it may be too prone to error.

The hierarchical clustering of the morphological measurements (Fig. 7) shows that the young children (infans I) are separated in a single cluster (cluster 2) from the infans II, juvenis, adultus and maturus (cluster 1). Cluster 2 is divided into two subclusters, 2a and 2b. The former consists mainly of infans II and juvenis, while the latter is dominated by adultus and maturus footprints. There are a few exceptions, as the footprints of subjects S9 and S14 (both adultus) are found in clusters 2a and 2b. S15, a juvenis female, is the only exception found in the adultus/maturus cluster 2b.

**Sex determination**

*Morpho-classificatory approach:* Examination of the demographic data of the 26 identified subjects shows a slight majority of male subjects, of which 15 were identified (Tab. 2), while 10 subjects were counted as

females. Sex could not be recorded for a single subject (S26).

*Morpho-metric approach:* Kanchan et al. were able to show in their study that FW and FHW are significantly greater in male subjects than in female subjects (2014: 30). Transferred to the corresponding measured distances of the footprints in Aldène, differentiated according to age classes, this result can be consistently confirmed for the FW, even if the differences are not very large (Tab. 3). The FHW, on the other hand, only corresponds to the result of Kanchan et al. for adult subjects. For female subjects in the juvenis and maturus age classes, the FHW are a little larger than for male subjects. However, for Kanchan et al. this does not seem to be exceptional, because “although the foot dimensions exhibit sexual dimorphisms, they are likely to be influenced by the stature and build of an individual.” (2014: 31)

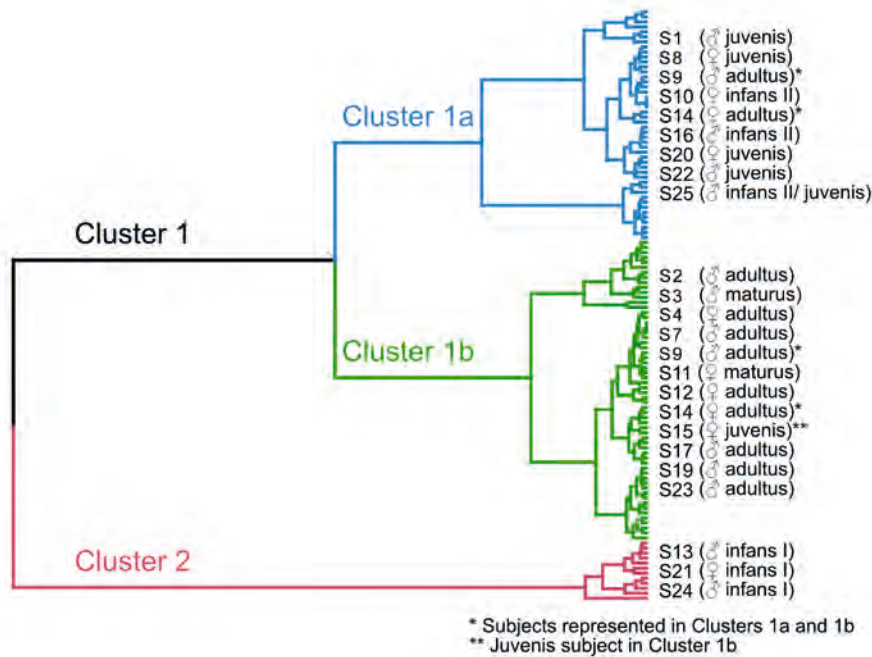

Fig. 7. Aldène. Hierarchical clustering of all footprints where all measurements (FL\*D1, FL\*D2, FW and FHW) could be recorded.  
 Abb. 7. Aldène. Hierarchische Clusteranalyse aller Fußabdrücke, für die alle Messwerte (FL\*D1, FL\*D2, FW und FHW) erfasst werden konnten.

**Age and body size estimation**

*Morpho-classificatory approach:* With regard to the age of the Mesolithic explorers, a wide range of age classes from infans I (up to six years) up to maturus (41-60 years) is present, with a balanced relationship (Tab. 2). As far as the physical aspect is concerned, most subjects seem to have been normally proportioned (N = 18), three are small (S5, S6 and S21), two are strong (S7 and S12), one is light (S20) and one is tall (S4). In the group as a whole, no anomalies could be detected in relation to a possible handicap of the locomotive system.

*Morpho-metric approach:* The results of the PCA already showed a separation of age along PC1 (see

above). With FW and max. FL loading very strongly on PC1 (Fig. 6), the PCA helped us to identify the most important variables that structure footprint variability, which is, in other words, dependent on size and in consequence on age. We therefore plotted the linear regression of both variables (Figs. 8 & 9) and they revealed a very good and significant linear relationship ( $r^2 = 0.8, p < 0.00$ ). First, along the regression line, we see again a separation of the subjects confirming the results made by morpho-classificatory approach (Fig. 8). And second, if the datapoints are classified according to age and sex, a clear trend from infans to maturus is visible along the regression line, with no clear separation of sex. In other words, the main

Distance	Male				Female			
	N	Range (mm)	Mean (mm)	Sd. (mm)	N	Range (mm)	Mean (mm)	Sd. (mm)
Juvenis								
FW	13	68-85	77.31	1.65	28	66-86	76.64	1.11
FHW	15	46-60	53.6	1.15	30	44-64	56.2	1.01
Adultus								
FW	28	80-94	85.64	0.65	21	76-93	82.43	1.07
FHW	27	50-66	61.11	0.73	17	54-71	57.59	1.04
Maturus								
FW	13	86-92	90.15	0.61	9	78-82	80.22	0.52
FHW	11	50-58	54.82	0.82	9	54-60	57.56	0.56

Tab. 3. Aldène. Foot dimensions for sex determination based on Kanchan et al. (2014), FW and FHW are significantly greater in male subjects than in female subjects.

Tab. 3. Aldène. Fußmaße zur Geschlechtsbestimmung nach Kanchan et al. (2014), FW und FHW sind bei männlichen Subjekten signifikant größer als bei weiblichen.

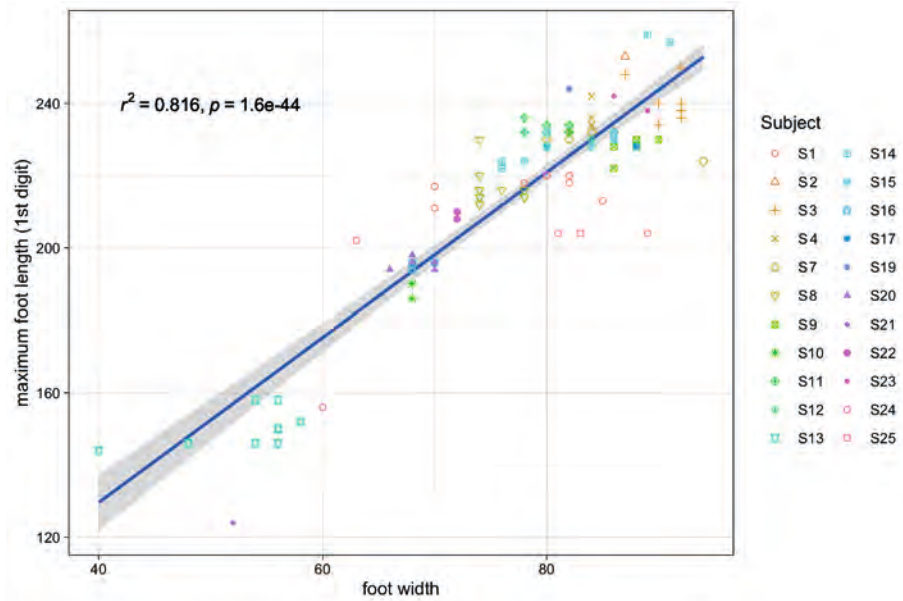

**Fig. 8.** Aldène. Plot with regression line of the variables max. FL (= FL\*D1) and FW of all footprints where all measurements (FL\*D1, FL\*D2, FW and FHW) could be recorded. The datapoints are coloured so that each colour corresponds to a subject identified by the morpho-classificatory approach.  
**Abb. 8.** Aldène. Diagramm mit Regressionslinie der Variablen max. FL (= FL\*D1) und FW aller Fußabdrücke, bei denen alle Messwerte (FL\*D1, FL\*D2, FW und FHW) erfasst werden konnten. Die Datenpunkte sind so eingefärbt, dass jede Farbe einem durch den morpho-klassifikatorischen Ansatz identifizierten Subjekt entspricht.

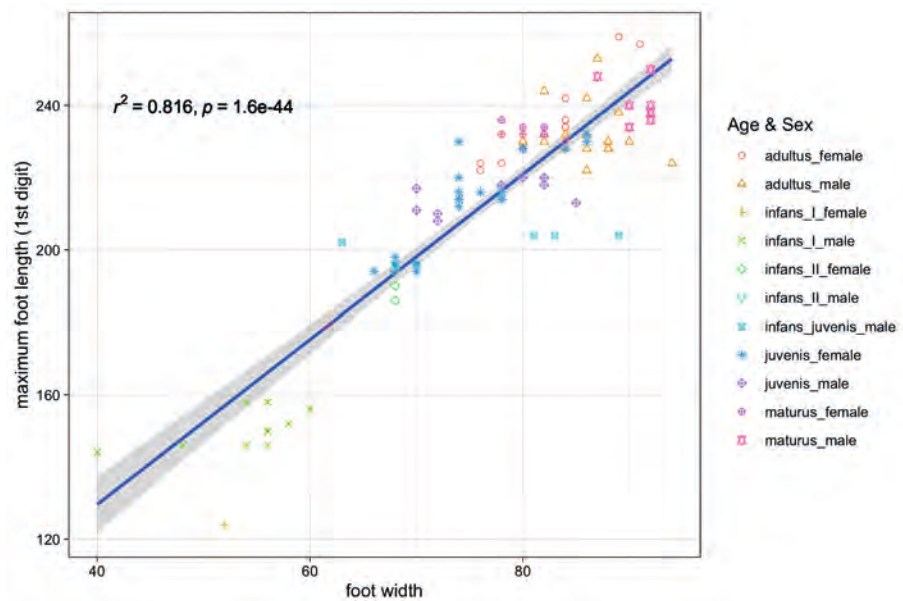

**Fig. 9.** Aldène. Plot with regression line of the variables max. FL (= FL\*D1) and FW of all footprints where all measurements (FL\*D1, FL\*D2, FW and FHW) could be recorded. The datapoints are coloured so that each colour corresponds to the age classes identified by the morpho-classificatory approach.  
**Abb. 9.** Aldène. Diagramm mit Regressionslinie der Variablen max. FL (= FL\*D1) und FW aller Fußabdrücke, bei denen alle Messwerte (FL\*D1, FL\*D2, FW und FHW) erfasst werden konnten. Die Datenpunkte sind so eingefärbt, dass jede Farbe den Altersklassen entspricht, die durch den morpho-klassifikatorischen Ansatz ermittelt wurden.

measurements, FW, FL\*D1 and FL\*D2 are strongly correlated, and their combination is an indicator of age. The max. FL is also used to estimate body size (Topinard 1876). Using this approach, an examination of the calculated body sizes in relation to the age classes differentiated by sex – generated by the

morpho-classificatory approach - reveals an interesting picture. (Fig. 10). First, the body sizes calculated for Aldène fall exactly within the values estimated by Piontek and Vančatab (2012) for Mesolithic hunter-gatherers - males (168 cm) and females (157 cm). Second, the body size increases in both sexes until the

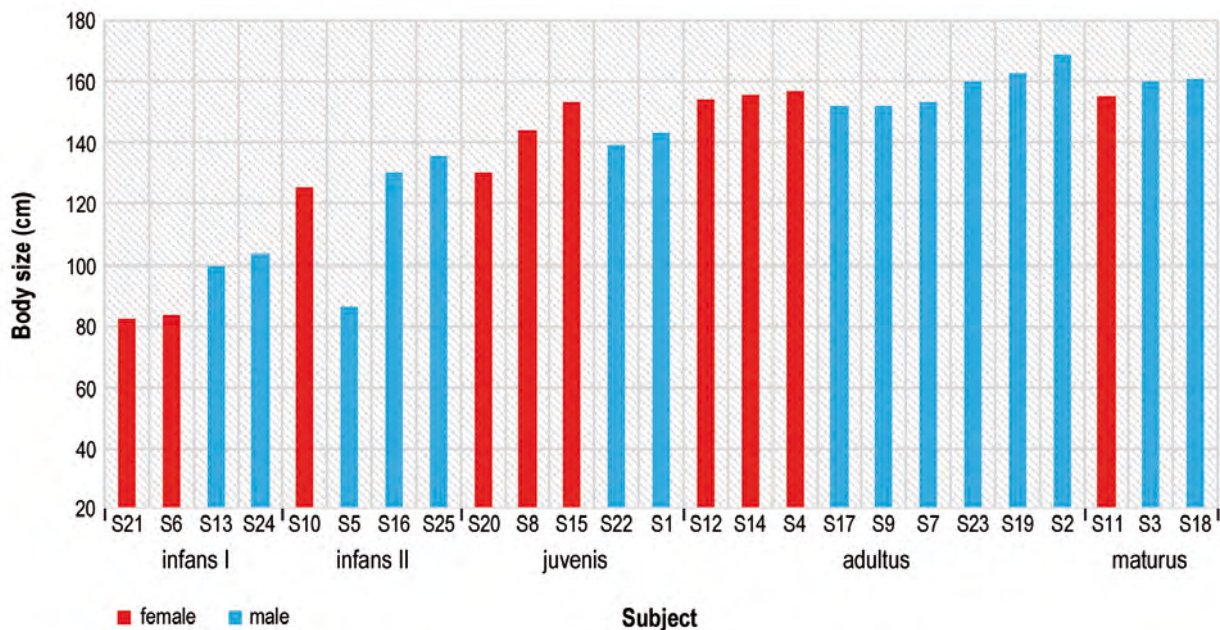

Fig. 10. Aldène. Calculated body size of trackmakers. Foot length corresponds to 15% of the body size (Topinard 1876). Grouped according to the results of the age class and sex assessments by the morpho-classificatory approach.

Abb. 10. Aldène. Berechnete Körpergröße der Subjekte, die Fußabdrücke hinterlassen haben. Die Fußlänge entspricht 15% der Körpergröße (Topinard 1876). Eingestuft nach den Ergebnissen der Alters- und Geschlechtsbestimmungen nach dem morpo-klassifikatorischen Ansatz.

end of the growth phase at juvenile age. After that, it remains constant. Furthermore, it is noticeable that the variation in body size is greater among the younger age classes than among the older age classes, whereby according to the morpho-classificatory approach three subjects of this group from the younger age classes are conspicuously small (S6, S21 and S5).

**Group configuration**

*Morpho-classificatory approach:* In addition to the observations already described, and based on the spatial distribution and references of the footprints to each other, various subjects have been identified who moved in six small groups:

- Group 1: S3 (male, maturus), S4 (female, adultus)
- Group 2: S5 (male, infans II), S6 (female, infans I)
- Group 3: S8 (female, juvenis), S9 (male, adultus)
- Group 4: S7 (male, adultus), S8 (female, juvenis) and S9 (male, adultus)
- Group 5: S11 (female, maturus), S13 (male, infans I)
- Group 6: S18 (male, maturus), S19 (male, adultus)

Some subjects (S3, S4, S8 and S13) were not only walking in one of these small groups, but also - at least temporarily - alone. On the premise that the footprints in the Paul Ambert gallery are the result of a single group visit, this behaviour may reflect a group dynamic process in which the constellations of the group members may have changed and mixed. Furthermore, other subjects (S1, S2, S10, S12, S14, S15, S16, S17, S20, S21, S22, S23, S24, S25 and S26) could not be assigned to any group. Whether they were really on their own or in some other, unidentifiable constellation must remain open.

**Carrying additional weight**

*Morpho-classificatory approach:* Four of the 26 subjects carried additional weight (S7, S9, S14 and S22), and four at least temporarily (S3, S4, S8 and S23). It is difficult to say anything certain about what was carried, but at least in sector C and D (14, see below) it was probably a baby, and otherwise in two cases something heavy.

Without any exception, all trackways and isolated footprints where the subjects carried additional weight lead towards the Mesolithic entrance of the cave (Tab. 4). Even if the data basis is not very extensive, a pattern becomes apparent namely that things were carried out of the cave. This is even more convincing when only the footprints of subjects are considered whose footprints could be identified in both walking directions. This concerns the eight subjects S3, S4, S8, S11, S13, S20, S23 and S25. None of them carried anything on the way to the deep part of the cave, but four subjects did on the way back (S3, S4, S8 and S23).

Consequently, these subjects must have picked up additional weight in the cave beyond the examined sectors and carried it in the direction of the Mesolithic entrance.

**Body postures, activity and gait**

*Morpho-classificatory approach:* In general, we distinguish between dynamic and static postures, even if in the static posture qualified activities were performed. Among the dynamic ones, the tracks from walking activity (N = 146) dominate. While the activity was aimed at the objective of locomotion, individual footprints provide clues to additional activities that were carried out while walking. These include playing (E7, E8), pulling a stick behind (E25,



Subject	Age class*	Direction/Additional weight	
		End	Entrance
S1	juvenis	without	-
S2	adultus	without	-
S3	maturus	without	with
S4	adultus	without	with
S5	infans II	-	without
S6	infans I	-	without
S7	adultus	-	with
S8	juvenis	without	with heavy
S9	adultus	-	with heavy
S10	infans II	-	without
S11	maturus	without	without
S12	adultus	without	-
S13	infans I	without	without
S14	adultus	-	with baby
S15	juvenis	-	without
S16	infans II	-	without
S17	adultus	-	without
S18	maturus	without	-
S19	adultus	without	-
S20	juvenis	without	without
S21	infans I	-	without
S22	juvenis	-	with
S23	adultus	without	with
S24	infans I	-	without
S25	infans II-juvenis	without	without
S26	infans I	-	without
Total		13	21

**Tab. 4.** Aldène. Trackmakers carrying additional weight split up according to walking direction - \*Martin 1928 - neonatus, infans I (0.5-6 years), infans II (7-13 years), juvenis (14-20 years), adultus (21-40 years), maturus (41-60 years) and senilis (>60 years).

**Tab. 4.** Aldène. Nach der Laufrichtung unterteilte Subjekte mit Zusatzgewicht - \*Martin 1928 - neonatus, infans I (0,5-6 Jahre), infans II (7-13 Jahre), juvenis (14-20 Jahre), adultus (21-40 Jahre), maturus (41-60 Jahre) und senilis (>60 Jahre).

E26), pulling the first toe through the clay (E37), pushing the baby up on the back (E20) and stepping over a block (E6). Six footprints indicate that the respective trackmaker lost the grip on the ground and slipped. This is not surprising on the loamy, partly slanting ground (E8, E14,

E18, E27, E36). The loss of the grip on the ground also led to the loss of balance on several occasions. In two cases the trackmakers had to interrupt the forward movement by taking up a stable stand (E18, E27), or by getting stuck in the loam (E38).

**Speed of walking**

*Morpho-classificatory approach:* During the dynamic postures, the speed of locomotion including slipping can be classified as fast for over 60 % of the footprints. Fast speed means an expeditious, safe walk without searching and hesitating. At this speed, one foot is always in contact with the ground. Only five footprints indicate normal, and 40 footprints indicate a slow walking speed. No statement about the walking speed could be made for eleven footprints. If the result described here is split into the two different walking directions - into the deep part of the cave and towards the Mesolithic entrance - for subjects whose walking direction could be documented in both directions (Tab. 5), it becomes clear that the largest proportion of footprints pointing into the deep part of the cave result from a slow locomotion (N = 19). Only a small testifies to a faster speed (N = 4). This is exactly the opposite for the walk to the Mesolithic entrance. Here, by far the largest number of footprints are of a fast speed (N = 42).

*Morpho-metric approach:* The observations described above can be complemented by the results of the measurement of the stride length of the same subjects. The respective mean values show that the distances of the locomotion to the deep part of the cave are shorter than those from the movement to the Mesolithic entrance (Tab. 6). Subject S8 is an exception, as it was walking fast in both directions.

The walking speed estimation based on the relationship between stride length and speed described by Dingwall et al. (2013) clearly shows that the walking speed in Aldène was basically not very high. The estimated speeds ranged from 1.0 to 5.5 km/h, covering the spectrum from slow to the basic speed of 1.3 m/s (4.68 km/h), which represents the optimal metabolic walking speed for unloaded walking (Bastien

Subject	End				Entrance				
	Fast	Normal	Slow	nts	Fast	Normal	Slow	nts	Total
S3	-	2	1	1	7	-	-	2	13
S4	-	-	2	-	6	-	-	-	8
S8	3	-	-	-	13	-	-	-	16
S11	-	-	4	2	3	-	-	-	9
S13	-	-	6	-	7	-	-	-	13
S20	1	-	-	-	5	-	-	-	6
S23	-	-	1	-	1	-	-	-	2
S25	-	-	5	-	-	-	2	-	7
Total	4	2	19	3	42	-	2	2	74

**Tab. 5.** Aldène. Speed estimation with morpho-classificatory approach.

**Tab. 5.** Aldène. Abschätzung der Geschwindigkeit mit Hilfe eines morpho-klassifikatorischen Ansatzes.

Morpho-classificatory approach				Morpho-metric approach										
Subject	Identity	Speed		Stride length (cm)		Mean FL (cm)	SL/avgFL		0.48*SL/mean FL		Speed (m/s)		Speed (km/h)	
		End	Entrance	End	Entrance		End	Entrance	End	Entrance	End	Entrance	End	Entrance
S3	male matusus	normal-slow	fast	-	132.3	24	-	5.51	-	2.65	-	1.26	-	4.5
S4	female adultus	slow	fast	-	117.2	23.6	-	4.97	-	2.38	-	0.99	-	3.6
S8	female juvenus	fast	fast	112.8	111.3	21.6	5.22	5.15	2.51	2.47	1.12	1.08	4.0	3.9
S11	female matusus	slow	fast	96.5	96.6	23.3	4.14	4.15	1.99	1.99	0.60	0.60	2.2	2.2
S13	male infans I	slow	fast	67.2	91.6	15	4.48	6.11	2.15	2.93	0.76	1.54	2.7	5.5
S20	female juvenus	fast	fast	-	113.3	19.6	-	5.78	-	2.77	-	1.38	-	5.0
S25	male infans II-juvenus	slow	slow	70.7	-	20.4	3.47	-	1.66	-	0.27	-	1.0	-

Tab. 6. Aldène. Speed estimation with Dingwall's method (Speed m/s =  $-1.39+0.48*(SL/mean \text{ max. FL})$  (Dingwall et al. 2013: 560, Tab. 1) in comparison with the results of the morpho-classificatory approach – SL = stride length, FL = foot length; nts = nothing to say.

Tab. 6. Aldène. Abschätzung der Geschwindigkeit mit der Dingwall-Methode (Geschwindigkeit m/s =  $-1,39+0,48*(SL/mittlere \text{ max. FL})$  (Dingwall et al. 2013: 560, Tab. 1) im Vergleich zu den Ergebnissen des morpho-klassifikatorischen Ansatzes - SL = Schrittlänge, FL = Fußlänge; nts = nichts zu sagen.

et al. 2005). This covers the slow, normal and fast categories used by the morpho-classificatory approach to describe the different walking speeds.

The walking speed estimations obtained by the different methods are identical except for one result. The divergence of the results concerns subject S11 on the way to the Mesolithic entrance of the cave. According to the result of the estimation with Dingwall's method, subject S11 walked at a speed of 2.2 km/h. This corresponds to a slow speed. According to the morpho-classificatory approach, subject S11 walked here at a fast speed. In this case, the different estimation is probably due to the different data base: while the morpho-classificatory approach had three footprints at their disposal, only one stride length could be measured using the morpho-metric approach.

In summary, it can be stated that the determined walking speeds were adapted to the environmental conditions in the cave (darkness, partly uneven, slippery floor with obstacles, partly low cave ceiling with possible risk of head injury). A running speed in which at times both feet have no contact with the ground was - and still is - not appropriate to the situation.

**Axis of locomotion and superimpositions of human tracks**

*Morpho-classificatory approach:* The consideration of the axis of locomotion (walking and slipping) confirms the central observations already described. The only motivation for cave visitors to pass through this part of the cave was to cross this area. We interpret the fact that there are significantly more footprints pointing towards

the Mesolithic entrance of the cave (N = 102) than towards the deep part of the cave (N = 54) as a logical consequence of the chronological sequence of events. The chronologically most recent footprints lead out of the gallery and partially overlap with those leading into the cave. A total of 17 superimpositions were identified where the identity of both trackmakers is known (Tab. 7). Involved are the 13 subjects S1, S3, S4, S7, S8, S9, S11, S12, S13, S15, S18, S19 and S22. On the one hand, the inclusion of information about the orientation of the relevant footprints clearly shows the existence of overlapping footprints pointing in the same direction. On the other hand, if they are in opposite directions, the footprints pointing towards the Mesolithic entrance are concluded to be younger (Fig. 11) than the footprints pointing towards the interior of the cave. Beyond this basic statement, it becomes clear that within three small groups, according to the group configuration using the morpho-classificatory approach - group 1 (S3 and S4), group 3 (S8 and S9) and group 5 (S11 and S13), the relevant subjects were at least temporarily walking behind each other and not side by side.

**Identified events**

*Morpho-classificatory approach:* In the Paul Ambert gallery of Aldène, 38 events were identified. The events with only one acting subject (N = 28) are more frequent than those in which several subjects were involved (N = 10).

Regarding the events described in detail below, it is noticeable that they represent exclusively passages, i.e., movements for the purpose of changing location from

	Footprints																
Upper	S3-3*	S3-4*	S3-9	S8-12	S9-7*	S11-1	S11-3*	S11-4	S13-5	S13-7	S13-9	S13-10	S13-11	S15-6	S15-7	S15-9	
Lower	S4-3*	S4-5*	S1-16	S8-16	S8-7*	S4-4	S13-2*	S1-12	S1-14	S7-7	S18-1	S7-8	S19-1	S19-2	S12-4	S22-1	S22-2

Tab. 7. Aldène. Superimpositions of human tracks (white/Mesolithic entrance, grey/deep part of the cave), members of a small group (\*).

Tab. 7. Aldène. Überlagerung menschlicher Fußabdrücke (weiß/mesolithischer Eingang, grau/tieferer Teil der Höhle), Mitglieder einer kleinen Gruppe (\*).



**Fig. 11.** Aldène. Superimposition from footprints S13-10 (pointing to the Mesolithic entrance) and S19-1 (pointing to the deep part of the cave) (Photo: Philippe Galant, Andreas Pastoors). Scale 25 cm.

**Abb. 11.** Aldène. Überlagerung der Fußabdrücke S13-10 (Richtung mesolithischer Eingang) und S19-1 (Richtung tieferer Teil der Höhle) (Foto: Philippe Galant, Andreas Pastoors). Maßstab 25 cm.

one point to another. In the case of the Paul Ambert gallery, these are paths further into the deep part of the cave or in the opposite direction to the Mesolithic entrance. In the course of these passages, the trackmakers reacted casually, certainly intuitively, to the conditions of the ground.

#### *Description of the identified events*

In the following paragraphs, the results of the identification of the Mesolithic footprints from Aldène are presented in spatial units, from the inside of the cave towards the Mesolithic entrance. The results are grouped according to the identified events. Project-internal numbers of the tracks (e.g. S8-1, S8-2 etc.) are used to identify the individual spoor. The footprints are always described in walking direction even if the numbering suggests otherwise.

#### **Sector A**

On the way from the deep part of the cave towards the Mesolithic entrance, sector A is the first area with Mesolithic footprints (Figs. 1 & 3).

- Event 11: An exceptionally long trackway along the cave wall was left by subject S1, a male juvenis, consisting of nine footprints - left (S1-1), right (S1-2), left (S1-3), right (S1-4), left (S1-5), right (S1-6), left (S1-7), right (S1-8) and left (S1-9) (Figs. 12 & 13). The

trackmaker walked slowly, without carrying additional weight, towards the deep part of the cave.

- Event 29: From subject S2, a male adult, only one footprint has been identified in the studied sector A. The footprint is from a left foot (S2-1) and points towards the deep part of the cave (Fig. 12). No statement can be made about the speed of subject S2, but it did not carry any additional weight.

#### **Sector C**

About 20 m further into the direction of the Mesolithic entrance, sector C opens up over a length of 30 m with the largest number of Mesolithic footprints (Figs. 1 & 3).

- Event 1: A very prominent event was found west of the central axis in sector C. Involved are a total of 14 footprints, eight from subject S3, a male matusus, and six from subject S4, a female adult. The 14 footprints can be grouped into three trackways. Only a single footprint (S3-9) is isolated from the others. First, the two subjects, S3 and S4, have been documented walking together in the southern part of sector C. Each of them has left a trackway there: subject S3 a trackway consisting of five footprints - right (S3-1), left (S3-2), right (S3-3), left (S3-4) and right (S3-5), and subject S4 a trackway consisting of six footprints - left (S4-2),



**Fig. 12.** Aldène, sector A: Projection of the footprints identified by the morpho-classificatory approach onto the orthophoto. Reading mode:  $S1-4^{11}$  – right footprint no. 4 of subject no. 1 which belongs to event no. 11 (grey scaled orthophoto based on 3D laser scan model, Orthophoto: IUT Nîmes/Géomesure, Infographic: Andreas Pastoors).

**Abb. 12.** Aldène, Sektor A: Projektion der mittels morpho-klassifikatorischem Ansatz identifizierten Fußabdrücke auf das Orthofoto. Lesemodus:  $S1-4^{11}$  - rechter Fußabdruck Nr. 4 von Subjekt Nr. 1, der zu Ereignis Nr. 11 gehört (grau skaliertes Orthofoto basierend auf 3D-Laserscanmodell, Orthofoto: IUT Nîmes/Géomesure, Infografik: Andreas Pastoors).



**Fig. 13.** Aldène, sector A, event E11: Part of a long trackway left by subject S1, a male juvenis – left (S1-1), right (S1-2) and left (S1-3) (Photo: Philippe Galant, Andreas Pastoors). Scale 50 cm.

**Abb. 13.** Aldène, Sektor A, Ereignis E11: Teil einer langen Fährte, die vom Subjekt S1, männlich juvenis, hinterlassen wurde - links (S1-1), rechts (S1-2) und links (S1-3) (Foto: Philippe Galant, Andreas Pastoors). Maßstab 50 cm.

right (S4-3), left (S4-4), right (S4-5), left (S4-6) and right (S4-7) (Figs. 14-16). Subject S4 moved differently from normal walking patterns, because she walked mainly on the forefoot. Whether this reflects a handicap or a personal habit must be left open. In the further course of sector C, only subject S3 can be traced by one trackway consisting of two footprints – right (S3-7) and right (S3-8) (Fig. 19). The left footprint in-between was not identified. Another single footprint (S3-9) is included in this event (Figs. 22 & 23). It is a right footprint of subject S3. All footprints point into the direction to the Mesolithic entrance and result from a fast locomotion. An exception is the isolated footprint S3-9, because here no statements could be made about the speed. Furthermore, the footprints indicate that the two subjects S3 and S4 carried additional weight.

- Event 2: Three more footprints left by subject S3, a male maturus, belong to a separate event. They all point towards the deep part of the cave and can be divided into a trackway (Fig. 23) and an isolated footprint (S3-6) (Fig. 18). The trackway comprises two footprints - right (S3-11) and left (S3-10), which were made at normal walking speed close to the western wall. For the isolated footprint (S3-6), also near the western wall, no statement can be made in

this regard. When walking into the cave, subject S3 did not carry any additional load.

- Event 3: Two more footprints were left by subject S4, a female adult, in sector C - left (S4-4) and right (S4-1). They are located in the eastern part of the sector close to the western wall, and their direction points towards the deep part of the cave. They can be considered as one trackway (Figs. 15 & 16), even if there are missing footprints in between. The walking speed was slow, and subject S4 did not carry any additional weight.

The following events E4, E5 and E6 certainly belong to the same activity, but since there is too much distance between the corresponding footprints, they are evaluated and described as individual events. Involved are three subjects – subject S7, a male adult, subject S8, a female juvenis, and subject S9, a male adult - who walked together in a group at all three spots towards the Mesolithic entrance of the cave at fast speed. A total of 36 footprints belong to these three events, which can be assigned to nine trackways and one isolated footprint (S9-9). All three subjects carried an additional weight, and subjects S8 and S9 even carried something heavy. Interestingly, the course of the three subjects is initially oriented towards the eastern wall.

- Event 4: This first part of the overall activity includes 14 footprints in the southern part of sector C. They



**Fig. 14.** Aldène, sector C, event E1: Detail from a prominent event of a total of 14 footprints from subject S3, a male matusus, and subject S4, a female adult, walking together. Subject S4 mainly walked on the forefoot (Photo: Philippe Galant, Andreas Pastoors). Scale 10 cm.

**Abb. 14.** Aldène, Sektor C, Ereignis E1: Ausschnitt eines markanten Ereignisses von insgesamt 14 Fußabdrücken von Subjekt S3, männlich matusus, und Subjekt S4, weiblich adult, die gemeinsam gehen. Subjekt S4 ging hauptsächlich auf dem Vorfuß (Foto: Philippe Galant, Andreas Pastoors). Maßstab 10 cm.

derive from the aforementioned subjects S7, S8 and S9, who oriented themselves close together along the eastern wall in this sector. The total of the 14 footprints can be divided into three trackways. Subject S7 left a trackway consisting of four footprints - left (S7-1), right (S7-2), left (S7-3) and left (S7-4) (Figs. 15 & 16). The right footprint in between was not identified. From subject S8 comes a trackway with a total of six footprints - right (S8-1), left (S8-2), right (S8-3), left (S8-4), right (S8-5) and left (S8-6) (Fig. 16). The trackway left by subject S9 consists of four footprints - left (S9-1), right (S9-2), left (S9-3) and right (S9-4). (Fig. 16)

- Event 5: The 13 footprints that are classified as event E5 are located in the central area of sector C, also near to the eastern wall. The three subjects S7, S8 and S9 left three short trackways here. Subject S7 left a trackway consisting of five footprints – right (S7-5), left (S7-6), right (S7-7), left (S7-8) and right (S7-9), subject S8 left a trackway consisting of four footprints – left (S8-7), right (S8-8), left (S8-9) and right (S8-10), and subject S9 finally left a trackway also consisting of four footprints – right (S9-5), left (S9-6), right (S9-7) and left (S9-8) (Fig. 19).
- Event 6: What is interesting about this event, which is composed of nine footprints, are the different reactions to an obstacle lying in the path of the three

subjects. The obstacles are five blocks of small dimensions with a maximum length of 50 cm. While subjects S7 and S8 stepped over the obstacle, subject S9 has swerved towards the western wall shortly before the obstacle, yet one cannot speak of an abrupt change of decision, but of a slow change of walking direction. The three trackways of the three subjects include relatively few footprints. Subject S7 left a trackway consisting of three footprints – left (S7-10), left (S7-11) and right (S7-12), subject S8 left a trackway consisting also of three footprints – right (S8-11), right (S8-12) and left (S8-13) - and subject S9 finally left a trackway consisting of two footprints – left (S9-10) and right (S9-11) (Fig. 23), and additionally an isolated right footprint (S9-9) (Fig. 22).

Like E4, E5 and E6, the events E7, E8 and E9 represent one and the same activity. Here, too, the spatial distances between the individual events are too large to allow to categorise them as one event. This time the two subjects S11, a female matusus, and S13, a male infans I, walked together into the deep part of the cave, orienting themselves on the western wall. They walked at a slow speed, with subject S13 even playing while walking. This is expressed in subject S13's slightly meandering gait. A total of 12 footprints belong to the three events, which can be assigned to three trackways and three isolated

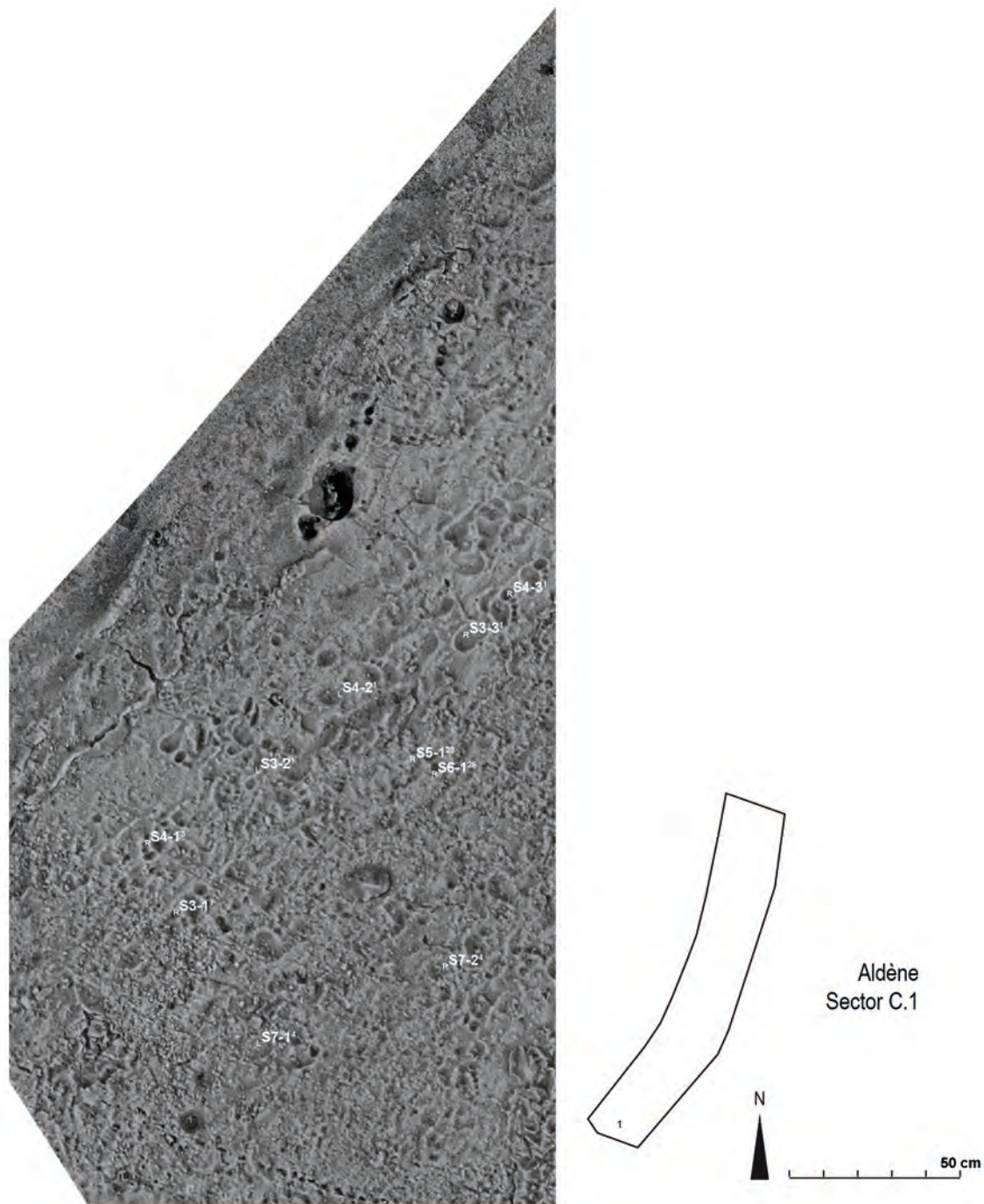

**Fig. 15.** Aldène, southernmost part of sector C: Projection of the footprints identified by the morpho-classificatory approach onto the orthophoto. Reading mode:  $\text{rS4-1}^3$  – right footprint no. 1 of subject no. 4 which belongs to event no. 3 (grey scaled orthophoto based on 3D laser scan model, Orthophoto: IUT Nîmes/Géomesure, Infographic: Andreas Pastoors).

**Abb. 15.** Aldène, südlichster Teil von Sektor C: Projektion der mittels morpho-klassifikatorischem Ansatz identifizierten Fußabdrücke auf das Orthofoto. Lesemodus:  $\text{rS4-1}^3$  - rechter Fußabdruck Nr. 1 von Subjekt Nr. 4, der zu Ereignis Nr. 3 gehört (grau skaliertes Orthofoto basierend auf 3D-Laserscanmodell, Orthofoto: IUT Nîmes/Géomesure, Infografik: Andreas Pastoors).

footprints (S11-5, S11-6 and S13-6). Both subjects did not carry any additional weight.

- Event 7: A total of seven footprints belong to this event. In the southern part of sector C, four footprints could be assigned to subject S11, all belonging to a short trackway - right (S11-4), left (S11-3), right (S11-2) and left (S11-1) (Fig. 16). Together with subject S11, subject S13 walked into the cave playing.

Subject S13 walked immediately in front of subject S11, which is suggested by superimpositions of footprints of the two subjects (Fig. 17). The three footprints of subject S13 were identified as one trackway - left (S13-3), right (S13-2) and right (S13-1), whereas the footprint in between could not be found (Fig. 16).

- Event 8: Only three footprints belong to this event in

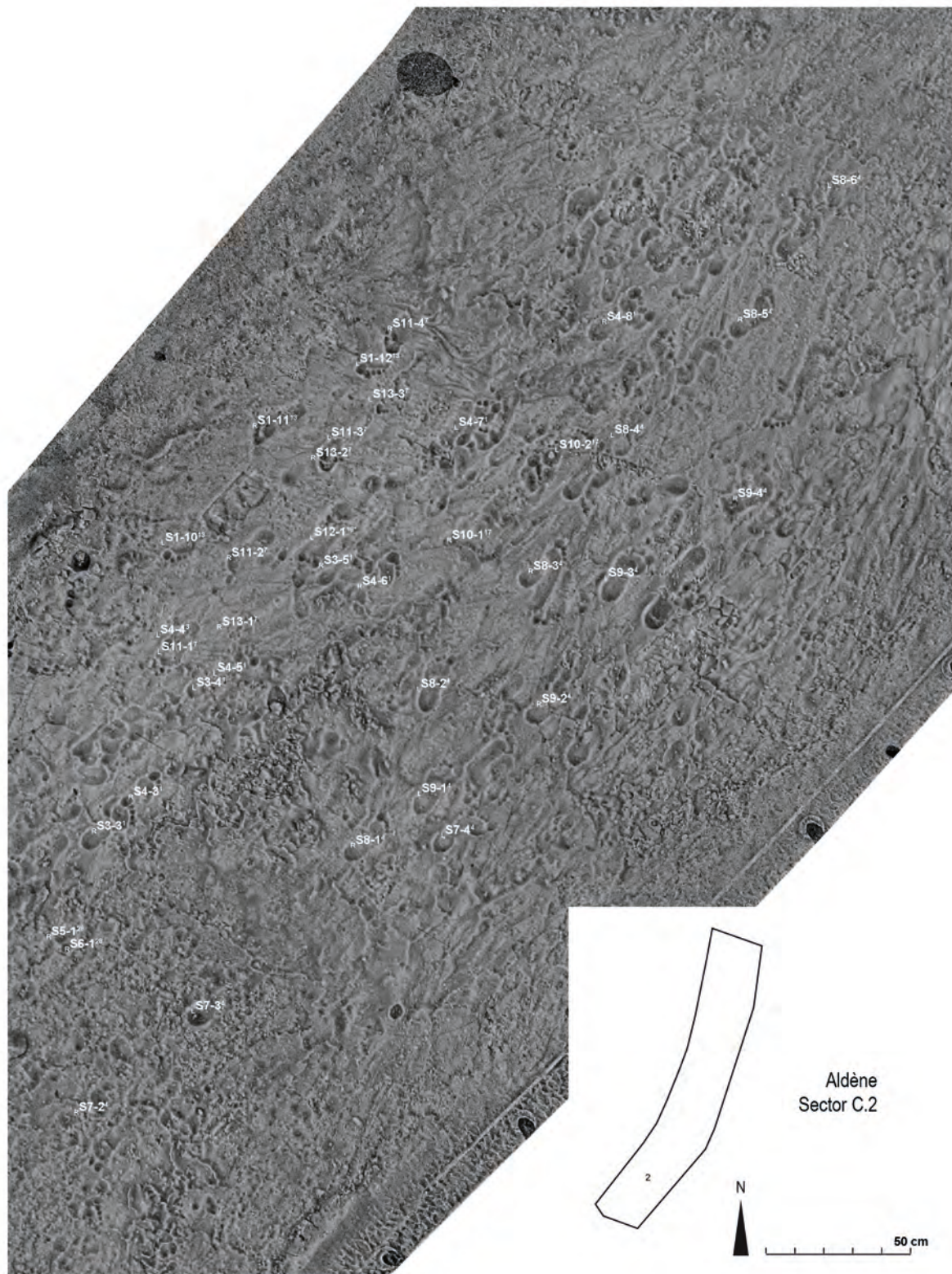

**Fig. 16.** Aldène, southern part of sector C: Projection of the footprints identified by the morpho-classificatory approach onto the orthophoto. Reading mode:  ${}_R S4-6^1$  – right footprint no. 6 of subject no. 4 which belongs to event no. 1 (grey scaled orthophoto based on 3D laser scan model, Orthophoto: IUT Nîmes/Géomesure, Infographic: Andreas Pastoors).

**Abb. 16.** Aldène, südlicher Teil von Sektor C: Projektion der mittels morpho-klassifikatorischem Ansatz identifizierten Fußabdrücke auf das Orthofoto. Lesemodus:  ${}_R S4-6^1$  - rechter Fußabdruck Nr. 6 von Subjekt Nr. 4, der zu Ereignis Nr. 1 gehört (grau skaliertes Orthofoto basierend auf 3D-Laserscanmodell, Orthofoto: IUT Nîmes/Géomesure, Infografik: Andreas Pastoors).





the centre of sector C. Two of them were assigned to subject S13 and an isolated footprint to subject S11 - left (S11-5). The two footprints of subject S13 belong to one trackway - left (S13-5) and right (S13-4) (Fig. 18). In footprint S13-4 it is evident that subject S13 slipped slightly at this point. However, this did not result in a fall.

- Event 9: Two isolated footprints, one each of subject S11- right (S11-6) and subject 13 – left (S13-6), belong to this event, which is also found in the centre of sector C (Fig. 19). As these are isolated footprints, not much can be said about the walking speed.
- Event 10: In the central area of sector C, 40 cm west of the central axis of the chamber, the five footprints of this event are found. They come from two subjects: S11, a female matusus, and S13, a male infans I, who already walked into the cave together in events E7, E8 and E9. At this point they walked together again, but in the direction of the Mesolithic entrance. While they were walking slowly when they entered the cave, they are now walking fast. In detail, subject S11 has left three footprints in a single trackway - left (S11-7), right (S11-8) and left (S11-9) (Fig. 23), subject S13 has left two footprints also in a single trackway – left (S13-12) and left (S13-13), while the right footprint between them could not be identified (Fig. 22). Both subjects did not carry any additional weight.
- Event 12: Exactly on the central axis of the gallery in the central part of sector C are the four footprints of this event. They were left by subjects S18, a male matusus, and S19, a male adult, each of whom left two footprints belonging to one trackway: from subject S18 were identified - left (S18-2) and right (S18-1), and from subject S19 - left (S19-2) and right (S19-1) (Fig. 19). Both trackways lead to the deep part of the cave, with subject S18 walking fast. No information could be given about the speed of subject S19. Both subjects were not carrying any additional weight.

As already described above, constellations can occur in which various individual events may in fact belong to the same activity. This also applies to the following case. The seven footprints, which are attributed to events E13, E14 and E15, all originate from subject S1, a male juvenis, from the walk into the deep part of the cave without

**Fig. 17.** Aldène, sector C, event E7: Two subjects S11, a female matusus, and S13, a male infans I, walked together into the deep part of the cave. They walked at a slow speed, with subject S13 even playing while walking. This is expressed in subject S13's slightly meandering gait (Orthophoto: Philippe Galant, Andreas Pastoors). Scale 50 cm.

**Abb.17.** Aldène, Sektor C, Ereignis E7: Zwei Subjekte, S11, weiblich matusus, und S13, männlich infans I, gingen gemeinsam in den tiefen Teil der Höhle. Sie gingen in einem langsamen Tempo, wobei Subjekt S13 während des Gehens sogar spielte. Dies zeigt sich im leicht mäandernden Gang von S13 (Orthofoto: Philippe Galant, Andreas Pastoors). Maßstab 50 cm.

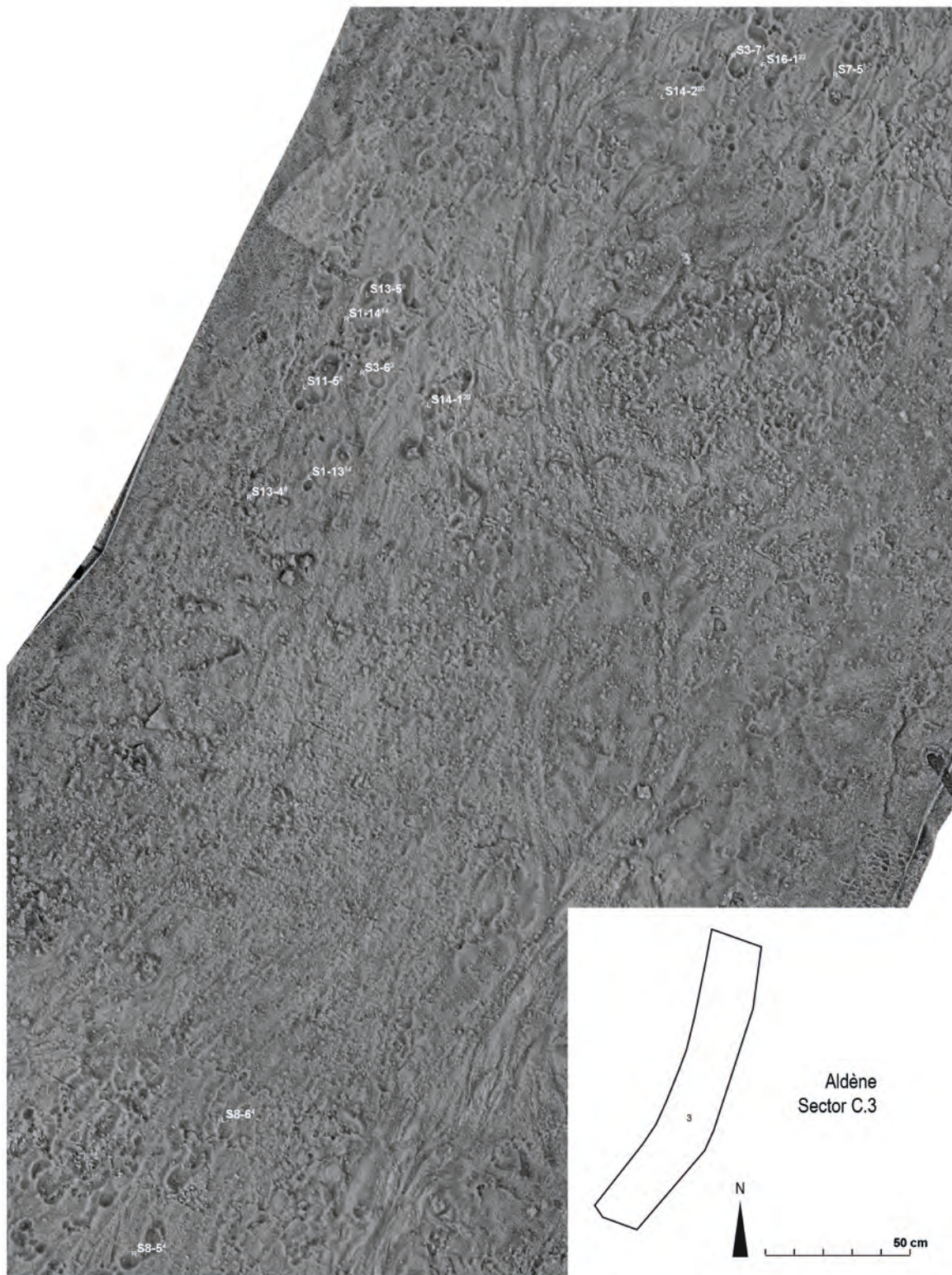

**Fig. 18.** Aldène, central part of sector C: Projection of the footprints identified by the morpho-classificatory approach onto the orthophoto. Reading mode:  $\text{R}S13-4^3$  – right footprint no. 4 of subject no. 13 which belongs to event no. 8 (grey scaled orthophoto based on 3D laser scan model, Orthophoto: IUT Nîmes/Géomesure, Infographic: Andreas Pastoors).

**Abb. 18.** Aldène, zentraler Teil von Sektor C: Projektion der mittels morpho-klassifikatorischem Ansatz identifizierten Fußabdrücke auf das Orthofoto. Lesemodus:  $\text{R}S13-4^3$  – rechter Fußabdruck Nr. 4 von Subjekt Nr. 13, der zu Ereignis Nr. 8 gehört (grau skaliertes Orthofoto basierend auf 3D-Laserscanmodell, Orthofoto: IUT Nîmes/Géomesure, Infografik: Andreas Pastoors).

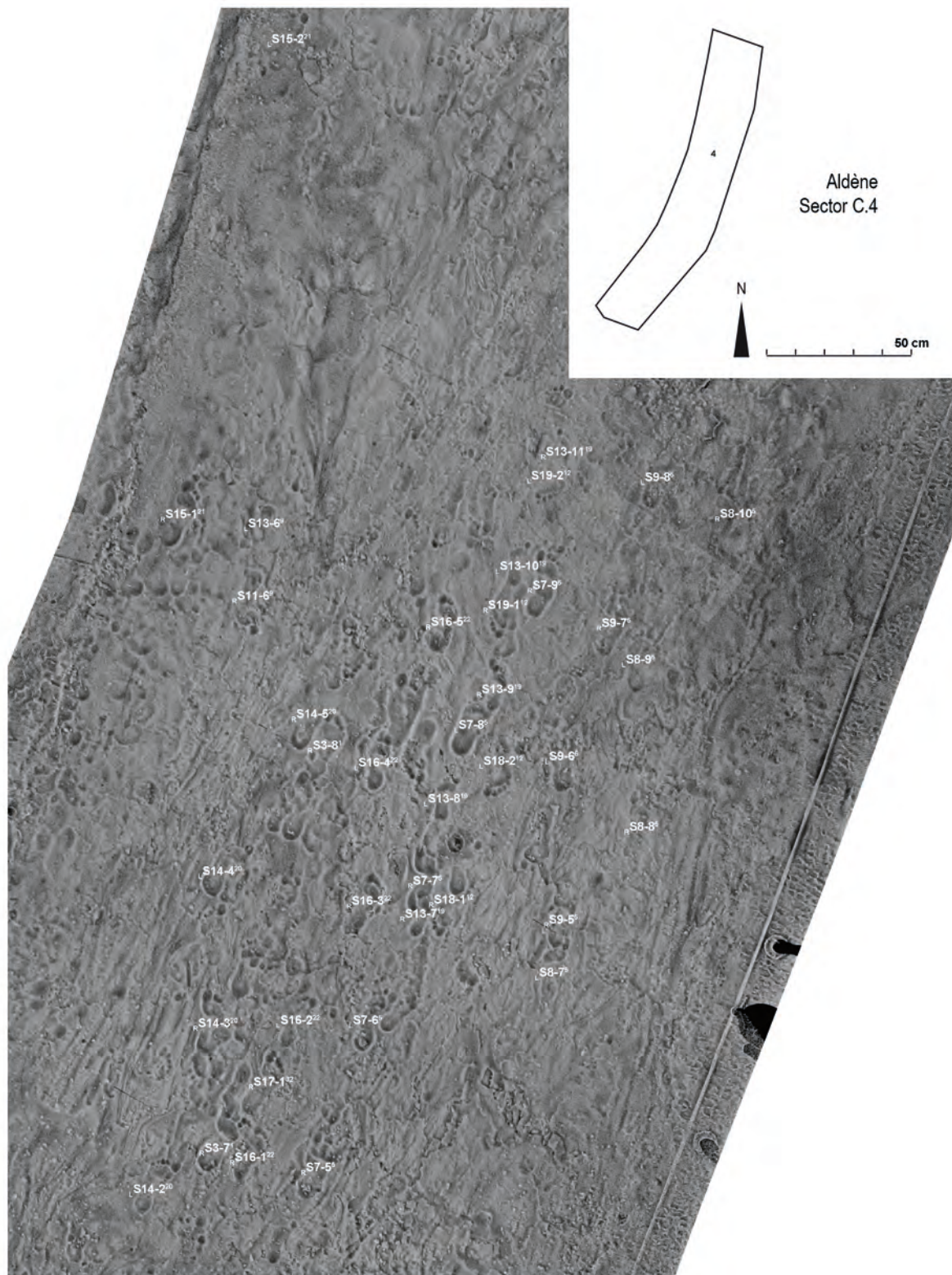

**Fig. 19.** Aldène, central part of sector C: Projection of the footprints identified by the morpho-classificatory approach onto the orthophoto. Reading mode:  ${}_R S3-8^1$  – right footprint no. 8 of subject no. 3 which belongs to event no. 1 (grey scaled orthophoto based on 3D laser scan model, Orthophoto: IUT Nîmes/Géomesure, Infographic: Andreas Pastoors).

**Abb. 19.** Aldène, zentraler Teil von Sektor C: Projektion der mittels morpho-klassifikatorischem Ansatz identifizierten Fußabdrücke auf das Orthofoto. Lesemodus:  ${}_R S3-8^1$  – rechter Fußabdruck Nr. 8 von Subjekt Nr. 3, der zu Ereignis Nr. 1 gehört (grau skaliertes Orthofoto basierend auf 3D-Laserscanmodell, Orthofoto: IUT Nîmes/Géomesure, Infografik: Andreas Pastoors).

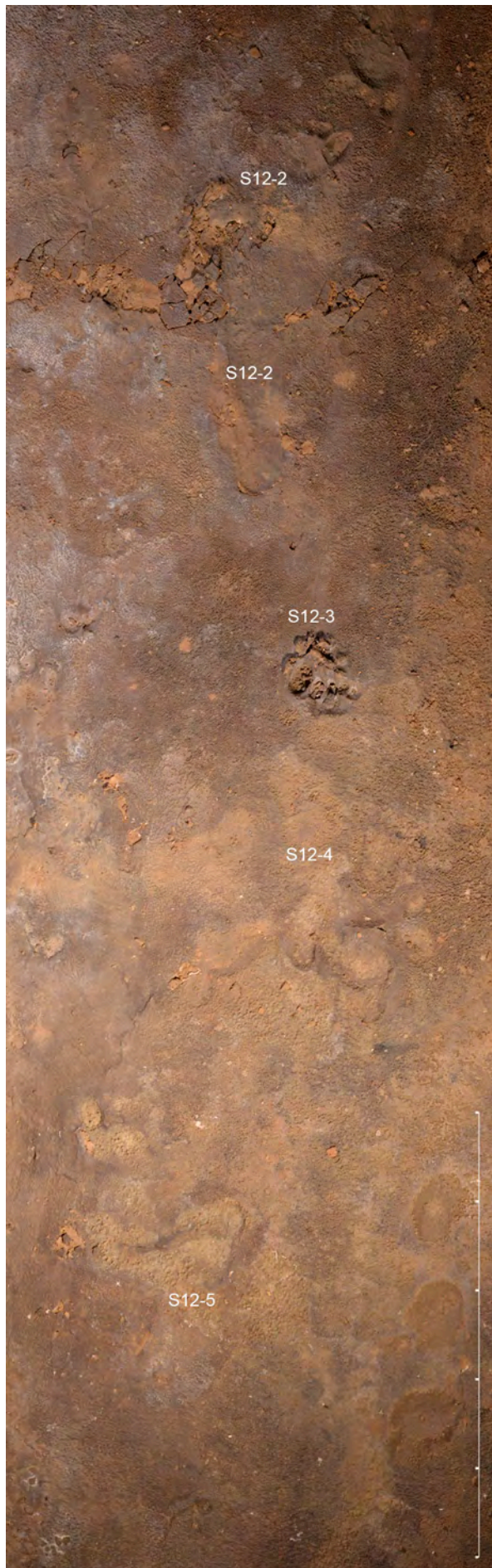

carrying any additional weight. Due to the large distances between the individual events, however, we refrained from combining them all into one event. When subject S1 walked into the deep part of the cave, its walking speed changed from fast to slow to normal afterwards. Accordingly, the footprints are divided into three trackways. Remarkable in the footprints of subject S1 is the conspicuously large first toe.

- Event 13: Three footprints from subject S1 were assigned to this event - left (S1-12), right (S1-11) and left (S1-10). The short trackway is located in the southern part of sector C and is oriented west of central axis of the cave (Fig. 16). The identified walking speed is normal at this point.
- Event 14: Also, along the western wall but a little further towards the Mesolithic entrance in the central area of sector C are the two footprints of this event. They belong to a trackway of subject S1 - right (S1-14) and left (S1-13) (Fig. 18). It is remarkable that he slipped forward at this point, but did not fall.
- Event 15: The footprints attributed to this event are located in the very northern area of sector C. They are again oriented towards the western wall and testify that the trackmaker walked at fast speed at this point. The two footprints of subject S1 again belong to a short trackway - right (S1-16) and left (S1-15) (Fig. 23).
- Event 16: In the northern area of sector C there are three footprints that were assigned to subject S8, a female juvenis, and represent a short trackway - right (S8-14), left (S8-15) and right (S8-16) (Fig. 23). Subject S8 was walking at fast speed along the eastern wall in direction to the deep part of the cave without carrying any additional weight.
- Event 17: In the southern part of sector C, on the central axis, two footprints were identified as belonging to subject S10, a female infans II, which form a short trackway - right (S10-1) and left (S10-2) (Fig. 16). With slow speed subject S10 walked into the direction to the Mesolithic entrance without carrying any additional weight.
- Event 18: To subject S12, a female adult, five

**Fig. 20.** Aldène, sector C, event E18: While walking fast into the direction of the deep part of the cave, subject S12, a female adult, managed a slippery passage. With her left foot (S12-5) she started to slip for about 3-4 cm. With her right foot (S12-4) she made a safe step, and then slipped again with her left foot (S12-2) for around 28 cm. She managed to stop slipping by pressing down the same foot in an oblique angle. To keep her balance, she then made a step backwards with her right foot (S12-3). Thereby the toes sank into clay (Orthophoto: Philippe Galant, Andreas Pastoors). Scale 50 cm.

**Abb. 20.** Aldène, Sektor C, Ereignis E18: Subjekt S12, weiblich adult, überwand eine rutschige Passage, während sie sich schnell in Richtung des tiefen Teils der Höhle bewegte. Mit dem linken Fuß (S12-5) rutschte sie etwa 3-4 cm weit vor. Mit dem rechten Fuß (S12-4) machte sie einen sicheren Schritt und rutschte dann wieder mit dem linken Fuß (S12-2) ca. 28 cm weit. Es gelang ihr, das Ausrutschen zu stoppen, indem sie denselben Fuß in einem schrägen Winkel auf dem Boden aufstellte. Um das Gleichgewicht zu halten, machte sie mit dem rechten Fuß einen Schritt nach hinten (S12-3). Dabei versanken die Zehen im Lehm (Orthofoto: Philippe Galant, Andreas Pastoors). Maßstab 50 cm.



footprints were assigned with four of them forming an interesting trackway – left (S12-5), right (S12-4), left (S12-2) and right (S12-3) (Fig. 23). The event happened in the northern part of sector C close to the western wall. While walking fast into the direction of the deep part of the cave, subject S12 managed a slippery passage. With her left foot (S12-5), she started slipping for about 3-4 cm. But with her right foot (S12-4) she made a safe next step, however then again, she slipped with her left foot (S12-2), for around 28 cm. She then managed to stop slipping by pressing the same foot down in an oblique angle. In order to maintain her balance, she then made a step backwards with her right foot (S12-3) (Fig. 20), with which she rammed her toes into the clay. A single additional left footprint (S12-1) attributed to subject S12 proves that she afterwards moved on (Fig. 16). On its way to the deep part of the cave, she did not carry any additional weight.

- Event 19: One trackway of five footprints was ascribed to subject S13, a male infans I – right (S13-7), left (S13-8), right (S13-9), left (S13-10) and right (S13-11) (Fig. 19). At this point of the central part of sector C he walked on the central axis at fast speed in direction to the Mesolithic entrance without carrying additional weight.
- Event 20: Six footprints that were identified as belonging to subject S14, a female adult, contain a special detail. Five of the six footprints form a trackway in the central part of sector C – left (S14-1), left (S14-2), right (S14-3), left (S14-4) and right (S14-5) (Fig. 19). While walking on the central axis of the chamber into the direction to the Mesolithic entrance and carrying additional weight, she changed speed from fast (S14-1) to slow (S14-2 to S14-5) to then accelerate again (S14-6) (Fig. 23). S14-6 is one isolated left footprint in the northern part of sector C that belongs probably to the same event despite the long distance between both spots. During the passage of the slow walk, subject S14 did a slight step to the left out of the walking axis, with the forepart of the foot sunk in deeply into the ground (Figs. 19 & 21). The whole event is

**Fig. 21.** Aldène, sector C, event E20: When walking towards the Mesolithic entrance subject S14, a female adult, carrying additional weight changed speed from fast (S14-1) to slow (S14-2 to S14-5) to then accelerate again (S14-6). During the passage of the slow walk subject S14 did a slight step to the left out of the walking axis, with the forepart of the foot sinking deeply into the ground. This is interpreted as the adjustment of a baby on her back into the right position (Orthophoto: Philippe Galant, Andreas Pastoors). Scale 50 cm.

**Abb. 21.** Aldène, Sektor C, Ereignis E20: Während des Gehens in Richtung des mesolithischen Eingangs wechselte Subjekt S14, weiblich adult, die zusätzliches Gewicht trug, die Geschwindigkeit von schnell (S14-1) zu langsam (S14-2 bis S14-5), um dann wieder zu beschleunigen (S14-6). Während der langsamen Gehphase machte Subjekt S14 einen leichten Schritt nach links aus der Gehachse heraus, wobei der vordere Teil des Fußes tief in den Boden gedrückt wurde. Dies wird so interpretiert, dass ein Baby auf dem Rücken an dieser Stelle in die richtige Position gebracht wurde (Orthophoto: Philippe Galant, Andreas Pastoors). Maßstab 50 cm.

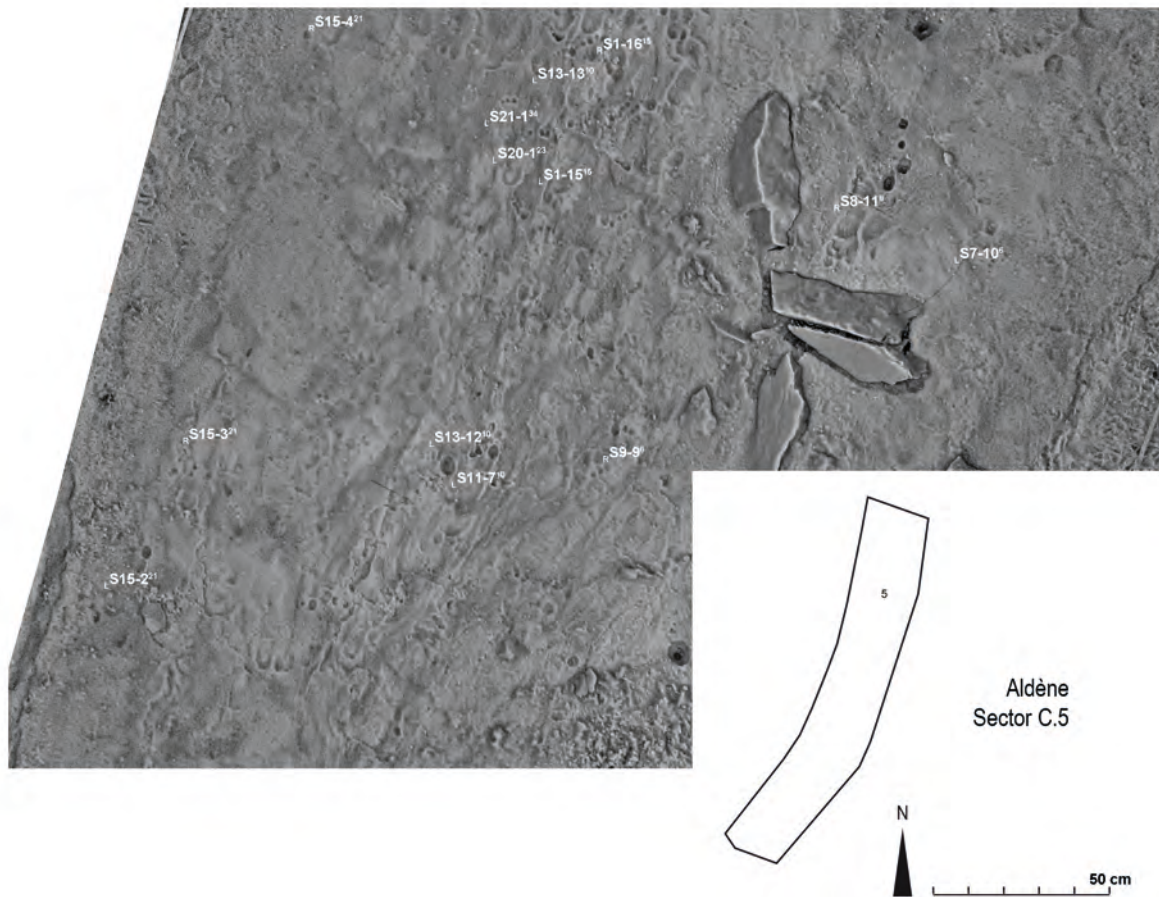

**Fig. 22.** Aldène, northern part of sector C: Projection of the footprints identified by the morpho-classificatory approach onto the orthophoto. Reading mode: S9-9<sup>6</sup> – right footprint no. 9 of subject no. 9 which belongs to event no. 6 (grey scaled orthophoto based on 3D laser scan model, Orthophoto: IUT Nîmes/Géomesure, Infographic: Andreas Pastoors).

**Abb. 22.** Aldène, nördlicher Teil von Sektor C: Projektion der mittels morpho-klassifikatorischem Ansatz identifizierten Fußabdrücke auf das Orthofoto. Lesemodus: S9-9<sup>6</sup> - rechter Fußabdruck Nr. 9 von Subjekt Nr. 9, der zu Ereignis Nr. 6 gehört (grau skaliertes Orthofoto basierend auf 3D-Laserscanmodell, Orthofoto: IUT Nîmes/Géomesure, Infografik: Andreas Pastoors).

interpreted as follows: Subject S14 carried a baby on her back, walked fast at first and then slowed down in the central area of sector C in order to push up the baby on her back into the right position. To do this, she made the slight step to the side and sunk with her forefoot deeper into the ground. Then she increased her speed again.

- Event 21: Close to the western wall in the central and northern part of sector C nine footprints were assigned to an exceptional long trackway of subject S15, a female juvenis, who walked at fast speed in direction to the Mesolithic entrance – right (S15-1), left (S15-2), right (S15-3), right (S15-4), left (S15-5), right (S15-6), left (S15-7), right (S15-8) and left (S15-9) (Figs. 19, 22 & 23). Subject S15 did not carry any additional weight.
- Event 22: Five footprints were ascribed to subject S16, a male infans II, that form a short trackway on the central axis of the central part of sector C – right (S16-1), left (S16-2), right (S16-3), left (S16-4) and right (S16-5) (Fig. 19). Subject S16 walked at fast speed in direction towards the Mesolithic entrance without additional weight.

- Event 23: Five footprints were ascribed to subject S20, a female juvenis, that form a single trackway in the northern part of sector C - left (S20-1), right (S20-2), left (S20-3), right (S20-4) and left (S20-5) (Fig. 23). At fast speed subject S20 walked without additional weight in direction to the Mesolithic entrance, leaving the central axis in direction of the western cave wall.
- Event 24: In the northern part of sector C, close to the western cave wall, two footprints forming a single trackway were ascribed to subject S22, a male juvenis - left (S22-1) and left (S22-2) (Fig. 23). At that spot subject S22 walked fast in direction to the Mesolithic entrance carrying additional weight.
- Event 28: Two right footprints (S5-1 and S6-1) were assigned to two different subjects - S5, a male infans II and S6, a female infans I - who walked together on the central axis in the southern part of sector C towards the Mesolithic entrance without additional weight (Figs. 15, 16 & 24). There is nothing to say about their walking speed.
- Event 32: To subject S17, a male adult, was ascribed one right footprint (S17-1) on the central axis of the

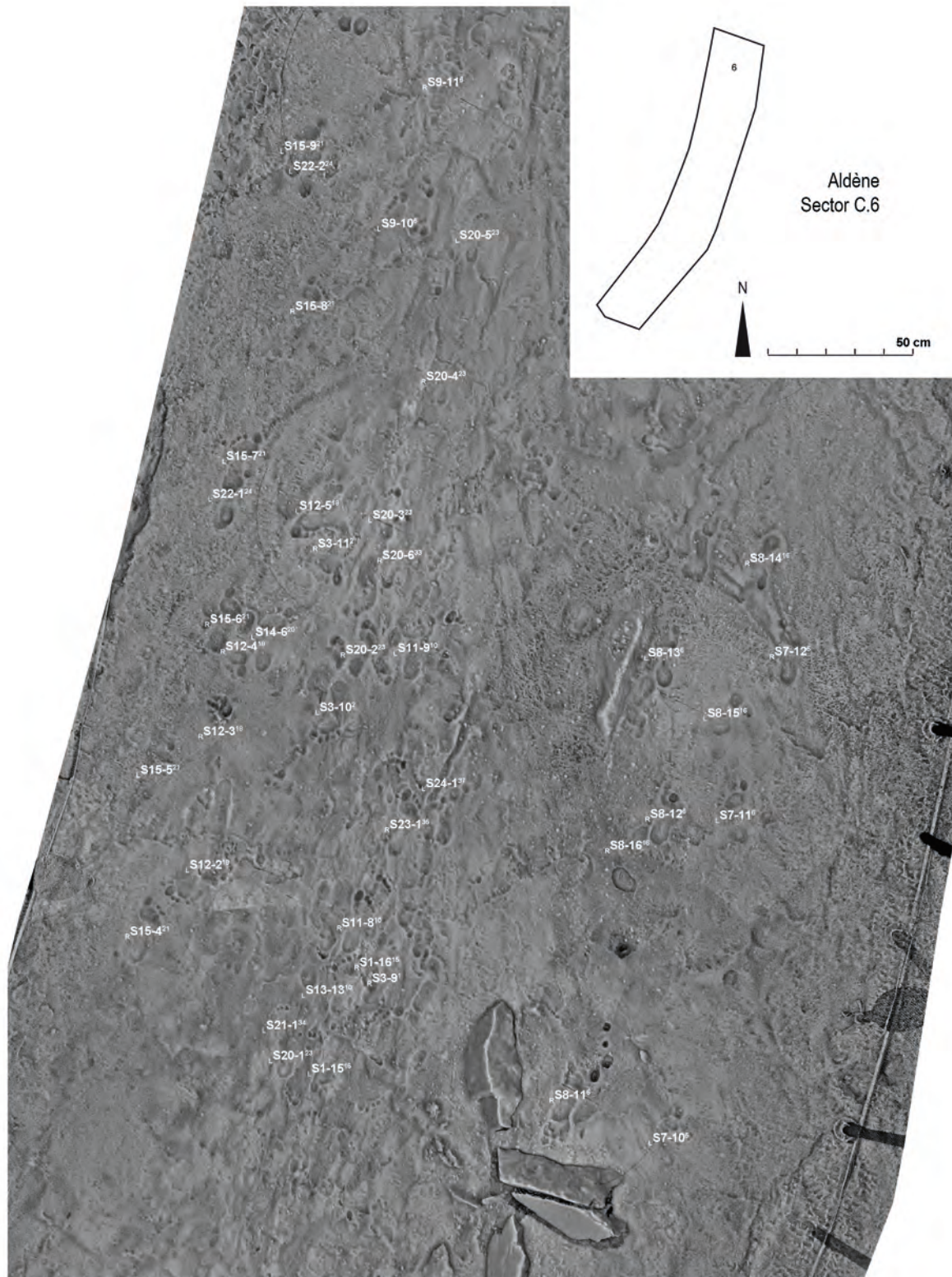

**Fig. 23.** Aldène, northernmost part of sector C: Projection of the footprints identified by the morpho-classificatory approach onto the orthophoto. Reading mode:  ${}_R$ S23-1<sup>35</sup> – right footprint no. 1 of subject no. 23 which belongs to event no. 35 (grey scaled orthophoto based on 3D laser scan model, Orthophoto: IUT Nîmes/Géomesure, Infographic: Andreas Pastoors).

**Abb. 23.** Aldène, nördlichster Teil von Sektor C: Projektion der mittels morpho-klassifikatorischem Ansatz identifizierten Fußabdrücke auf das Orthofoto. Lesemodus:  ${}_R$ S23-1<sup>35</sup> – rechter Fußabdruck Nr. 1 von Subjekt Nr. 23, der zu Ereignis Nr. 35 gehört (grau skaliertes Orthofoto basierend auf 3D-Laserscanmodell, Orthofoto: IUT Nîmes/Géomesure, Infografik: Andreas Pastoors).



**Fig. 24.** Aldène, sector C, event E28: Two right footprints (S5-1 and S6-1) were assigned to two different subjects - S5, a male infans II and S6, a female infans I - who walked together in direction to the Mesolithic entrance (Photo: Philippe Galant, Andreas Pastoors). Scale 10 cm.

**Abb. 24.** Aldène, Sektor C, Ereignis E28: Zwei rechte Fußabdrücke (S5-1 und S6-1) wurden zwei verschiedenen Subjekten zugeordnet - S5, männlich infans II, und S6, weiblich infans I - die sich gemeinsam in Richtung des mesolithischen Eingangs bewegten (Foto: Philippe Galant, Andreas Pastoors). Maßstab 10 cm.

central part of sector C (Fig. 19). Subject S17 walked without additional weight in direction to the Mesolithic entrance. There is nothing to say about walking speed.

- Event 33: In the northern part of sector C, west of the central axis, one right footprint (S20-6) was ascribed to subject S20, a female juvenis (Fig. 23). At that point subject S20 walked fast without carrying additional weight in direction to the deep part of the cave.
- Event 34: Also, in the northern part of sector C, on the central axis, one left footprint (S21-1) was assigned to subject S21, a female infans I (Figs. 22 & 23). Subject S21 walked fast with her toes gripping into the ground in direction to the Mesolithic entrance without carrying additional weight.
- Event 35: One right footprint (S23-1) was assigned to subject S23, a male adult, on the central axis of the northern part of sector C (Fig. 23). Subject S23 walked fast with additional weight in direction to the Mesolithic entrance.
- Event 37: On the central axis of the northern part of sector C an isolated left footprint (S24-1) was assigned to subject S24, a male infans I (Figs. 23 & 25). Subject S24 was not simply walking slowly without additional weight in direction to the Mesolithic entrance, he was dragging his first toe of the same left

foot behind and formed a line of around 45 cm length and 2.6-2.8 cm width into the ground.

#### Sector D

The transition between sectors C and D is rather smooth, with sector D being directly in an acute-angled curve, while sector C is straight (Figs. 1 & 3).

- Event 25: In the northern part of sector D subject S25, a male infans-juvenis, walked slowly without additional weight, pulling a stick through the soft cave floor, towards the deep part of the cave. Five successive footprints belong to this event, forming one short trackway – right (S25-1), left (S25-2), right (S25-3), left (S25-4) and right (S25-5) (Figs. 26 & 27). The trace of the stick runs approximately straight in a western direction, which corresponds to the direction of subject S25. The trace is 61.2 cm long and 1.8 to 3 cm wide.
- Event 26: Immediately close to event E25 in the centre of sector D subject S25, a male infans-juvenis, has left another two footprints – right (S25-6) and left (S25-7) that belong to another short trackway (Figs. 26 & 28). This time the footprints point into the direction of the Mesolithic entrance. Subject S25 again was pulling a stick, walked with the same slow speed, and carried no additional weight. The trace





**Fig. 25.** Aldène, sector C, event E37: Subject S24, a male infans I, walked slowly towards the Mesolithic entrance while dragging his first toe of the same left foot behind and formed a line of around 45 cm length and 2.6-2.8 cm width (Photo: Philippe Galant, Andreas Pastoors). Scale 10 cm.  
**Abb. 25.** Aldène, Sektor C, Ereignis E37: Subjekt S24, männlich infans I, bewegte sich langsam in Richtung des mesolithischen Eingangs und zog dabei die erste Zehe des linken Fußes hinter sich her, wobei er eine Linie von etwa 45 cm Länge und 2,6-2,8 cm Breite erzeugte (Foto: Philippe Galant, Andreas Pastoors). Maßstab 10 cm.

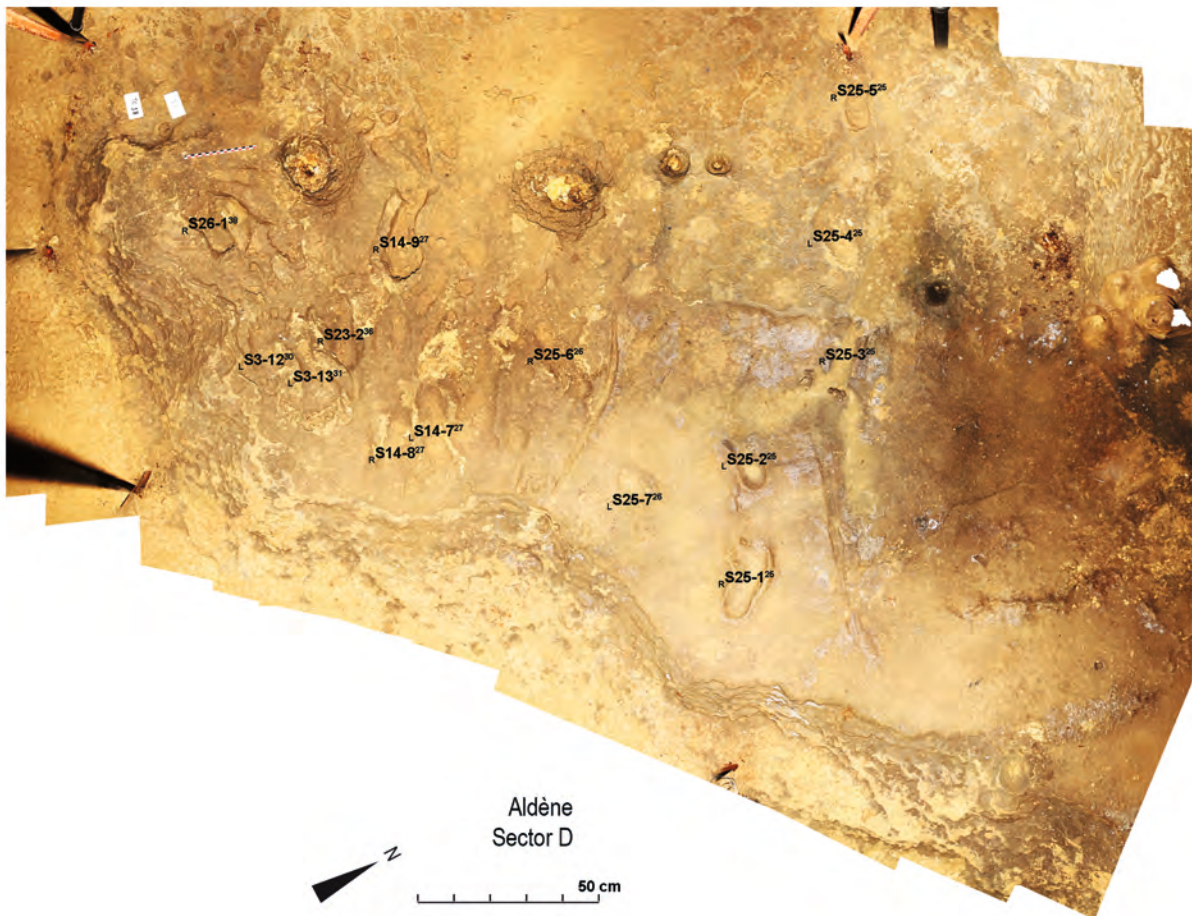

**Fig. 26.** Aldène, sector D: Projection of the footprints identified by the morpho-classificatory approach onto the orthophoto. Reading mode:  $^R$ S25-6<sup>26</sup> – right footprint no. 6 of subject no. 25 which belongs to event no. 26 (grey scaled orthophoto based on 3D laser scan model, Orthophoto: Thierry Montesinos, Infographic: Andreas Pastoors).

**Abb. 26.** Aldène, Sektor D: Projektion der mittels morpho-klassifikatorischem Ansatz identifizierten Fußabdrücke auf das Orthofoto. Lesemodus:  $^R$ S25-6<sup>26</sup> – rechter Fußabdruck Nr. 6 von Subjekt Nr. 25, der zu Ereignis Nr. 26 gehört (grau skaliertes Orthofoto basierend auf 3D-Laserscanmodell, Orthofoto: IUT Nimes/Géomesure, Infografik: Andreas Pastoors).

of the stick runs in a slight curve in eastern direction, which corresponds to the walking direction of subject S25. The trace of the stick is 58 cm long and 1.8 to 2.8 cm wide. Due to similar dimensions, it seems reasonable to assume that this spoor and that of event E25 come from one and the same stick.

- Event 27: Also, in a relatively central position of sector D, subject S14, a female adult, slipped with her right foot (S14-9) in slow speed in direction to the Mesolithic entrance. Even though she carried additional weight, subject S14 managed to place both feet next to each other - left (S14-7) and right (S14-8) - and thus maintained balance just in front of a low but noticeable step, the eastern edge of the sinter basin, forming this interesting trackway (Figs. 26 & 29).
- Event 30: At the southern edge of the sinter basin subject S3, a male maturus, has left one footprint (S3-12) in direction towards the deep part of the cave, originating from possibly walking with slow speed and without carrying any additional weight (Figs. 26 & 30).
- Event 31: Without intersecting with his own footprint

from the way into the cave, subject S3, a male maturus, has set his left foot (S3-13) immediately next to the left footprint (S3-12) (Figs. 26 & 30) described in event E30. This time the footprint points towards the Mesolithic entrance of the cave and likely results from locomotion at fast speed without carrying additional weight.

- Event 36: Also, at the southern edge of the sinter basin, the footprint of subject S23, a male adult, is found on the way into the deep part of the cave. With slow speed, subject S23's right foot (S23-2) came into slipping (Fig. 26). How he kept his balance is not documented in sector D. Subject S23 did not carry any additional weight.
- Event 38: Subject S26, an infans I of unknown sex, got stuck in the mud with the right foot (S26-1), standing in a static position facing towards the Mesolithic entrance of the cave (Figs. 26 & 31). At this point in the southernmost part of sector D, some calcareous crusts have formed on the floor and it looks as if subject S26's foot had gone under such a crust and bumped the front of his toes. Furthermore, he did not carry any additional weights.



**Fig. 27.** Aldène, sector D, event E25: Subject S25, a male infans-juvenis, walked slowly, pulling a stick through the soft cave floor, towards the deep part of the cave (Photo: Philippe Galant, Andreas Pastoors). Scale 50 cm.

**Abb. 27.** Aldène, Sektor D, Ereignis E25: Subjekt S25, männlich infans-juvenis, ging langsam, einen Stock durch den weichen Höhlenboden ziehend, in Richtung des tiefen Teils der Höhle (Foto: Philippe Galant, Andreas Pastoors). Maßstab 50 cm.

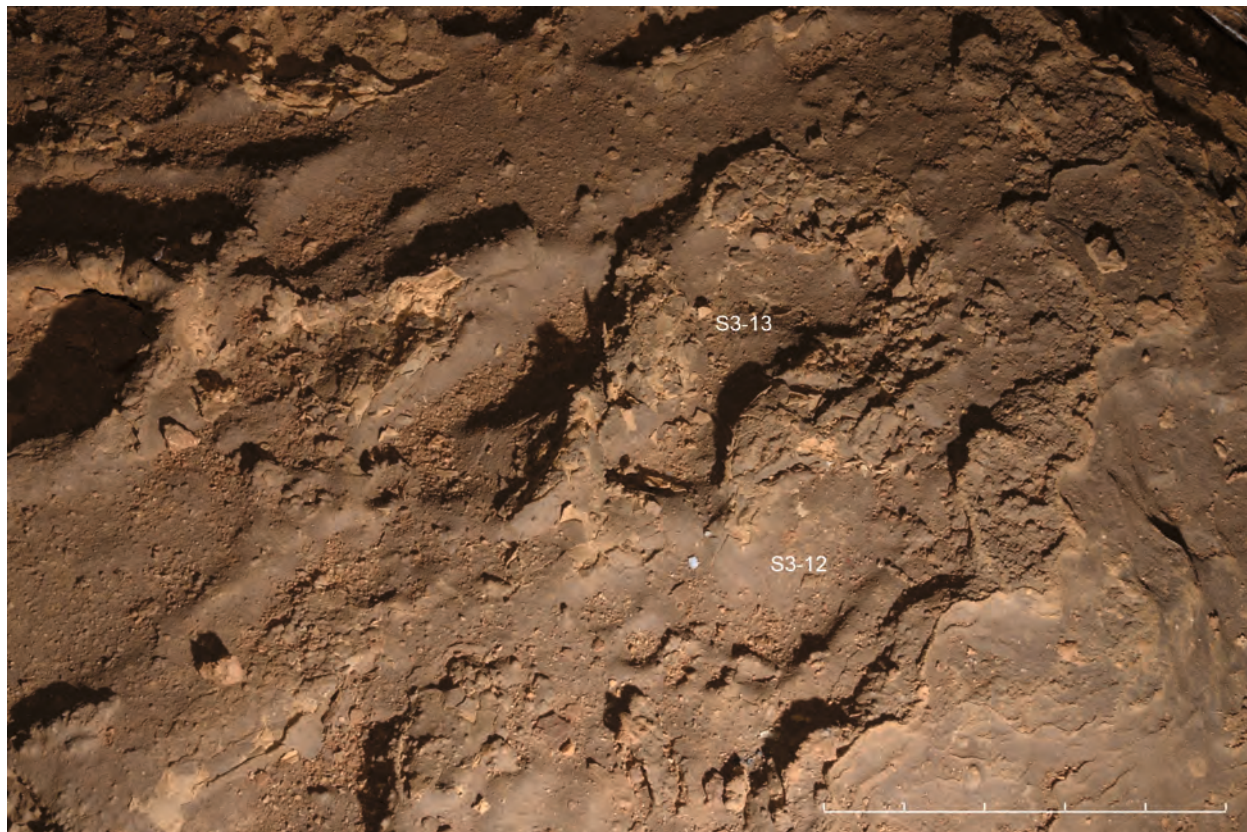

**Fig. 28.** Aldène, sector D, event E26: Immediately close to event E25 subject S25, a male infans-juvenis, has left another two footprints pointing into the direction of the Mesolithic entrance while again pulling a stick through the ground (Photo: Philippe Galant, Andreas Pastoors). Scale 25 cm.  
**Abb. 28.** Aldène, Sektor D, Ereignis E26: Unmittelbar in der Nähe des Ereignisses E25 hat S25, männlich infans-juvenis, zwei weitere Fußspuren hinterlassen, die in Richtung des mesolithischen Eingangs zeigen, während er erneut einen Stock durch den Boden zog (Foto: Philippe Galant, Andreas Pastoors). Maßstab 25 cm.



**Fig. 29.** Aldène, sector D, event E27: Subject S14, a female adult, slipped with her right foot (S14-9) while walking in a slow speed towards the Mesolithic entrance. Instead of falling down she managed to place both feet next to each other - left (S14-7) and right (S14-8) - and thus maintained balance just in front of a low but noticeable step, the eastern edge of the sinter basin (Photo: Philippe Galant, Andreas Pastoors). Scale 25 cm.

**Abb. 29.** Aldène, Sektor D, Ereignis E27: Subjekt S14, weiblich adult, rutschte mit dem rechten Fuß (S14-9) bei langsamer Geschwindigkeit in Richtung des mesolithischen Eingangs aus. Anstatt zu fallen, gelang es ihr, beide Füße nebeneinander zu setzen - den linken (S14-7) und den rechten (S14-8) - und so das Gleichgewicht zu halten, direkt vor einer niedrigen, aber spürbaren Stufe, dem östlichen Rand des Sinterbeckens (Foto: Philippe Galant, Andreas Pastoors). Maßstab 25 cm.



**Fig. 30.** Aldène, sector D, events E30 and E31: Subject S3, a male maturus, used almost the same passage for the way into the deep part of the cave as for the way back to the Mesolithic entrance (Photo: Philippe Galant, Andreas Pastoors). Scale 25 cm.

**Abb. 30.** Aldène, Sektor D, Ereignisse E30 und E31: Subjekt S3, männlich maturus, benutzte fast denselben Abschnitt, um in den tiefen Teil der Höhle zu gelangen, wie um zum mesolithischen Eingang zurückzukehren (Foto: Philippe Galant, Andreas Pastoors). Maßstab 25 cm.

## Discussion and Conclusion

The objective of this contribution was to compile as much information as possible about the Mesolithic footprints in the Paul Ambert gallery of the Aldène cave, employing a multi-method approach. In view of the considerable quantity and quality of the footprints at Aldène, it can be concluded that this strategy was an appropriate choice and has yielded favorable results. The question thus arises as to the extent to which the results obtained by the morpho-classificatory approach can be reproduced or evaluated with the morpho-metric approach. The present article can only make an indirect contribution to this, as its purpose is not to test the applicability and credibility of the two methods, but rather to present the results of the morpho-classificatory approach in detail and to complement them with those of the morpho-metric approach. In this regard, it is demonstrated that, whenever feasible, the results obtained by the morpho-classificatory approach can be enhanced by the application of statistical analyses in the context of the morpho-metric approach. The integration of these two approaches has resulted in a more comprehensive understanding with no instances of contradictory findings. This substantiates the value of integrating these two approaches as a unified methodology.

In recent years, a number of publications have brought prehistoric human footprints back into focus (Bennett et al. 2020; Burns 2021; Bustos et al. 2018; Citton et al. 2017; Duveau et al. 2019; Ledoux et al. 2021; Masao et al. 2016; Mayoral et al. 2021; McLaren et al. 2018; Ortega Martínez et al. 2021; Ortega-Martínez et al. 2020; Webb et al. 2006b). These works have not only established a methodological framework for the documentation of footprints in which photogrammetry and morpho-metric analyses play a major role, but have also shown that experiments for the generation of reference data sets are becoming increasingly important (McLaren et al. 2021). As with our quantitative-qualitative study, experiments may be regarded as a means of gathering experience, thus providing a qualitative foundation for quantitative methods. As Liebenberg has described in detail, tracking is a special skill that is a prerequisite for human hunting and can therefore be considered the beginning of science (Liebenberg 1990). In pre-industrial societies comprising hunter-gatherers and pastoralists, the ability to read tracks is an existential necessity. The skill is acquired from an early age and requires ongoing learning and practice throughout one's lifetime. The reference to personal experience and direct contact with the subject under observation simultaneously indicates that tracking necessitates a significant degree of tacit knowledge (Polanyi 1966),



**Fig. 31.** Aldène, sector D, event E38: Subject S26, infans I of unknown sex, got stuck in mud with its right foot, resting in a static position facing towards the Mesolithic entrance of the cave (Photo: Philippe Galant, Andreas Pastoors). Scale 10 cm.

**Abb. 31.** Aldène, Sektor D, Ereignis E38: Subjekt S26, ein Kind der Altersklasse infans I unbekanntes Geschlechts, blieb mit dem rechten Fuß im Schlamm stecken, in statischer Position mit Blick zum mesolithischen Höhleneingang (Foto: Philippe Galant, Andreas Pastoors). Maßstab 10 cm.

encompassing insights and cognitive abilities that are not explicitly articulated but are accessible to each individual through a process of embodied learning.

Even if not made explicit in the description of their research methods, there has already been an interlocking of quantitative and qualitative data in current research on prehistoric human footprints. We like to illustrate this briefly with some of the most recent examples. The first two are the work of Ledoux in Cussac cave (Ledoux 2019) and that of Duveau in Le Rozel (Duveau 2019). Both sites are located in France. In Cussac cave, the challenge was to understand the taphonomic processes after the formation of the footprints because the contours of the prints are blurred. Thanks to experiments on the sedimentation processes, Ledoux was able to ensure that the footprints were covered by water after formation, but without significant transport energy. At Le Rozel, the situation of interpreting the footprints was similarly difficult, because the footprints were formed in sand that did not solidify afterwards. This was a particular challenge during excavations and made the interpretation of the events problematic (Duveau 2019). In this case, too, experiments were carried out to understand the natural context of the formation and preservation of footprints.

Another recent discovery documents the possible interaction between humans and animals. To our knowledge the longest double trackway of a prehistoric

subject in the world has been found in White Sand National Park (North America). The trackway is about 800 m long and documents the outward and return path of this subject (Bennett et al. 2020). The trackway is crossed by tracks of a giant ground sloth and at three locations by tracks of a Columbian Mammoth. In the latter case, the subject did not react, at least according to the footprints; therefore, the tracks came into existence independently, or the human subject did not change track despite the appearance of the large animal (or vice versa). To the contrary, at Location-3F, the giant ground sloth turned on its own axis at the exact spot where it crossed the two human trackways, precisely in-between the outward and return journeys of the human trackmaker. Here, the human scent was probably noticed by the giant ground sloth, whose tracks appear to show a predator awareness (Bennett et al. 2020, Fig. 12). In this interpretation the interlocking of quantitative and qualitative data becomes particularly clear, as it is based on measurable data from the tracks of individual animals and humans, combined with non-measurable observations of their behaviour.

Even though the footprints in the Aldène cave were made in a completely different context, as no contemporaneous animals crossed the path and most tracks are perfectly preserved, the above-mentioned works already demonstrate that the morpho-metric approach alone is not sufficient to interpret footprints in

maximum possible depth. Experimental knowledge for the study of footprints in Cussac and Le Rozel was generated to build a data basis for the interpretation. Furthermore, the example from the White Sand National Park shows that experiential knowledge flows into the interpretation without this being explicitly stated: the individual footprints show a very large variability in the morpho-metric analysis and are nevertheless assigned to one subject (Bennett et al. 2020) not because the morpho-metric data suggest it irrefutably, but because they "look like" a consecutive trackway.

With regard to Aldène cave, the site in the White Sand National Park is also significant because the footprints indicate that a child was at least occasionally carried there (Bennett et al. 2020). The argumentation is identical at both sites: there is evidence of at least one child in each case via footprints. The temporary absence of these footprints is interpreted through the hypothesis that the children were carried. In Aldène cave, the qualitative morpho-classificatory approach provided additional arguments: here, a combination of steps is documented, which is interpreted as a balancing step resulting from moving a weight (possibly a child) carried on the back. The fact that children also played a role in other Prehistoric cave visits is also attested in Bàsrua cave (Italy) and Tuc d'Audoubert (France). In both caves, two small children under the age of six were identified (Avanzini et al. 2021; Pastoors et al. 2021).

As in the White Sand National Park, the same path was used in Aldène cave for the outward and return travel. This is not so surprising for Aldène, as there was no alternative for the way back. The comparison is nevertheless significant because an event of little temporal depth was documented at both sites. In Aldène it was the exploration of the cave to a certain point, in White Sand National Park the motivation of the path travelled is unknown (Bennett et al. 2020).

Another detail of the traces in Aldène has a parallel elsewhere. In two places in Aldène the trace of a stick was identified. In Willandra (Australia), the imprint of a spearhead was found in the ground in several places, which had been placed on the ground by its bearer while standing at a rest (Webb 2021; Webb et al. 2006b). Particularly spectacular, however, is the discovery of the tracks of a support pole that a one-legged man had used to help him move around (Webb et al. 2006a; Webb 2021). The traces at Aldène should certainly be interpreted differently, as there is no evidence of a physical limitation on the part of Mesolithic cave visitors. Instead, they prove the use of sticks as an accompaniment to exploring unknown terrain.

The intense interaction with the plastic surface and the mastery of even difficult passages with the temporary loss of balance as documented in Aldène is also documented in many other sites with footprints (Bennett et al. 2020; Lenssen-Erz et al. 2018; Pastoors et al. 2015). Only at one site, in Tuc d'Audoubert, did a loss of control occur and the subject lost balance and fell (Pastoors et al. 2021). Otherwise, the lack of falls indicates that the

walking speed was always adapted to the respective environment and strategies of fall avoidance were applied. With regard to movements in caves, this means that the footprints originate from experienced cave visitors who had known the special milieu with darkness, artificial lighting, intermittent plastic underground and obstacles. This experience in exploring caves has already been shown in the management of lighting (Galant et al. 2007).

So far, the sites we used for comparison have ignored chronology. Two sites are important in the context of Mesolithic human footprints. Both Formby Point (England) and Ojo Guareña (Spain) have provided sufficient footprints (Burns 2021; Ortega Martínez & Martín Merino 2013, 2019; Ortega Martínez et al. 2021; Ortega-Martínez et al. 2020; Roberts 2009). Formby Point is located on the Sefton coast in the northwest of England and documents the shared use of animals and humans of a coastal landscape including the mudflats, where the tides set the temporal rhythm. The human footprints date between 6,284-5,999 calBP and 6,672-6,402 calBP (Burns 2021). Much more comparable to the findings in Aldène cave is Ojo Guareña cave near Burgos (Spain). In this huge cave system, more than 1,000 footprints have been found in the best studied rooms alone - Sala and Galerías de las Huellas. These have been assigned to at least 18 trackways by 8-10 subjects (Ortega Martínez et al. 2021). Due to the lack of other material remains at Ojo Guareña, it is assumed that these footprints originate from the exploration of these cave parts. Even though there is a very large temporal depth in the footprints, ranging from 4,200 to 18,900 calBP, three dates from <sup>14</sup>C dated charcoal samples around 7,700 calBP attest that people were also in the cave during the Mesolithic (Ortega Martínez et al. 2021: 336).

There is no situation directly comparable to Aldène at any of the sites mentioned. Each has its own individual profile and only single elements are comparable with Aldène. In summary, it has been shown that the combination of both, the morpho-classificatory and the morpho-metric approaches allow to draw a number of conclusions from footprint sites, which in turn shed light on human behaviour in general and in specific situations.

**ACKNOWLEDGEMENT:** Research was funded by the DFG German Science Foundation ('Die Volp-Höhlen — Untersuchungen an einer Schlüsselfundstelle zur Kontextualisierung paläolithischer Felsbilder'; applicants: Andreas Pastoors, Thorsten Uthmeier; project identifier: DFG-Projektnummer 522090020 and 'Episoden aus dem Leben eiszeitlicher Höhlenkünstler; applicant: Thorsten Uthmeier; project identifier: DFG-Projektnummer 348042688), the cooperation with the Heinrich-Barth-Institute is gratefully acknowledged. Also, we are grateful for the support provided by Thierry Montesinos (the municipality of Cesseras), Gérard Gérola and Jean-Marc Benoit (both Institut Universitaire de Technologie de Nîmes), and Jean-Pierre Tessier (Société Géomesure) for the digital topographical recording in Aldène, as well as the members of the Aldène Association, whose help is always invaluable. Furthermore, we would like to express our gratitude to the reviewers for their constructive feedback, which has significantly improved the quality of the article.



## Literatur

- Alexander, R.M. (1984). Stride length and speed for adults, children, and fossil hominids. *American Journal of Physical Anthropology* 63: 23–27.
- Ambert, P., Colomer, A. & Galant, P. (2000). Datations mésolithiques des empreintes humaines de l'étage Cathala de la grotte d'Aldène (Cesseras, Hérault). *Comptes Rendus de l'Académie des Sciences - Series II A - Earth and Planetary Science* 331 (1): 67–74.
- Ambert, P., Galant, P., Guendon, J.-L. & Colomer, A. (2007). Les gravures et les empreintes humaines de la grotte d'Aldène (Cesseras, Hérault) dans leur contexte chronologique et culturel. *Bulletin du Musée d'Anthropologie Préhistorique de Monaco* 47: 3–36.
- Avanzini, M., Salvador, I., Starnini, E., Arobba, D., Caramiello, R., Romano, M. et al. (2021). Following the Father Steps in the Bowels of the Earth: The Ichneological Record from the Bäsura Cave (Upper Palaeolithic, Italy). In: A. Pastoors & T. Lenssen-Erz (Eds.), *Reading prehistoric human tracks. Methods and material*. Springer Nature, Cham, 251–276.
- Bastien, G.J., Willems, P.A., Schepens, B. & Heglund, N.C. (2005). Effect of load and speed on the energetic cost of human walking. *European journal of applied physiology* 94 (1-2): 76–83.
- Bennett, M.R., Bustos, D., Odess, D., Urban, T.M., Lallensack, J.N., Budka, M. et al. (2020). Walking in mud: Remarkable Pleistocene human trackways from White Sands National Park (New Mexico). *Quaternary Science Reviews* 249: 106610.
- Bennett, M. R. & Morse, S. A. (2014). *Human Footprints: Fossilised Locomotion?* Springer, Cham, s.l.
- Bennett, M. R. & Reynolds, S. C. (2021). Inferences from footprints. Archaeological best-practice. In: A. Pastoors & T. Lenssen-Erz (Eds.), *Reading prehistoric human tracks. Methods and material*. Springer Nature, Cham, 15–40.
- Burns, A. (2021). The Mesolithic Footprints Retained in One Bed of the Former Saltmarshes at Formby Point, Sefton Coast, North West England. In: A. Pastoors & T. Lenssen-Erz (Eds.), *Reading prehistoric human tracks. Methods and material*. Springer Nature, Cham, 295–316.
- Bustos, D., Jakeway, J., Urban, T.M., Holliday, V.T., Fenerty, B., Raichlen, D.A. et al. (2018). Footprints preserve terminal Pleistocene hunt? Human-sloth interactions in North America. *Science Advances* 4 (4): 1–6.
- Citton, P., Romano, M., Salvador, I. & Avanzini, M. (2017). Reviewing the upper Pleistocene human footprints from the 'Sala dei Misteri' in the Grotta della Bäsura (Toirano, northern Italy) cave. An integrated morphometric and morpho-classificatory approach. *Quaternary Science Reviews* 169: 50–64.
- Dingwall, H.L., Hatala, K.G., Wunderlich, R.E. & Richmond, B.G. (2013). Hominin stature, body mass, and walking speed estimates based on 1.5 million-year-old fossil footprints at Illet, Kenya. *Journal of Human Evolution* 64 (6): 556–568.
- Duveau, J. (2019). *Les empreintes de pieds du Rozel (Manche). Instantanés de groupes humains au Pléistocène supérieur. Approche combinée morphométrique et expérimentale*. Dissertation, Muséum National D'Histoire Naturelle, Paris.
- Duveau, J., Berillon, G., Verna, C., Laisné, G. & Cliquet, D. (2019). The composition of a Neandertal social group revealed by the hominin footprints at Le Rozel (Normandy, France). *Proceedings of the National Academy of Sciences of the United States of America* 116 (39): 19409–19414.
- Elder, J.H. & Goldberg, R.M. (2002). Ecological statistics of Gestalt laws for the perceptual organization of contours. *Journal of Vision* 2: 324–353.
- Fitzek, H. & Salber, W. (1996). *Gestaltpsychologie*. Wissenschaftliche Buchgesellschaft, Darmstadt.
- Galant, P. (2017). *Cesseras (Hérault) - Grotte d'Aldène. Étude paléoanthropologique des empreintes de pieds humains de la galerie Paul Ambert dans le réseau Cathala*, Mission 2017.
- Galant, P., Ambert, P. & Colomer, A. (2021). Prehistoric Speleological Exploration in the Cave of Aldène in Cesseras (Hérault, France). Human Footprint Paths and Lighting Management. In: A. Pastoors & T. Lenssen-Erz (Eds.), *Reading prehistoric human tracks. Methods and material*. Springer Nature, Cham, 277–294.
- Galant, P., Ambert, P., Colomer, A. & Guendon, J.-L. (2007). Les vestiges d'éclairages préhistoriques de la galerie des Pas de la grotte d'Aldène (Cesseras, Hérault). *Bulletin du Musée d'Anthropologie Préhistorique de Monaco* 47: 37–80.
- Galili, T. (2015). dendextend: an R package for visualizing, adjusting and comparing trees of hierarchical clustering. *Bioinformatics* 31 (22): 3718–3720.
- Graham, L. (2008). Gestalt Theory in Interactive Media Design. *Journal of Humanities and Social Sciences* 2: 1–11.
- Guendon, J.-L., Ambert, P., Quinif, Y., Baumes, B., Colomer, A., Dainat, D. et al. (2004). Ages et modalités des incursions humaines et animales préhistoriques dans l'étage Cathala de la grotte d'Aldène. Apport des analyses sédimentologiques et géochronologiques. *Karstologia* 43: 27–38.
- Hatala, K.G., Roach, N.T. & Behrensmeyer, A.K. (2022). Fossil footprints and what they mean for hominin paleobiology. *Evolutionary Anthropology* 32 (1): 39–53.
- Hotelling, H. (1933). Analysis of a complex of statistical variables into principal components. *Journal of Educational Psychology* 24 (6): 417–441.
- Kanchan, T., Krishan, K., Prusty, D. & Mechado, M. (2014). Heel–Ball index: An analysis of footprint dimensions for determination of sex. *Egyptian Journal of Forensic Sciences* 4: 29–33.
- Kanchan, T., Menezes, R.G., Moudgil, R., Kaur, R., Kotian, M.S. & Garg, R.K. (2008). Stature estimation from foot dimensions. *Forensic Science International* 179 2-3: 241.e1-5.
- Kassambara, A. & Mundt, F. (2020). *factoextra: Extract and Visualize the Results of Multivariate Data Analyses*.
- Krishan, K., Kanchan, T. & DiMaggio, J.A. (2015). Emergence of forensic podiatry. A novel sub-discipline of forensic sciences. *Forensic Science International* 255: 16–27.
- Le, S., Josse, J. & Husson, F. (2008). FactoMineR: An R Package for Multivariate Analysis. *Journal of Statistical Software* 25 (1): 1–18.
- Ledoux, L. (2019). *L'ichnologie préhistorique et les traces d'activités au sein des cavités ornées. Les grottes de Fontanet (Ariège) et de Cussac (Dordogne)*, Dissertation, Université de Bordeaux, Bordeaux.
- Ledoux, L., Berillon, G., Fourment, N., Muth, X. & Jaubert, J. (2021). Evidence of the use of soft footwear in the Gravettian cave of Cussac (Dordogne, France). *Scientific Reports* 11 (1): 22727.
- Lenssen-Erz, T. & Pastoors, A. (2021). Reading spoor. Epistemic aspects of indigenous knowledge and its implications for the archaeology of prehistoric Human Tracks. In: A. Pastoors & T. Lenssen-Erz (Eds.), *Reading prehistoric human tracks. Methods and material*. Springer Nature, Cham, 101–118.
- Lenssen-Erz, T., Pastoors, A., Ciqae, T., Kxunta, I., Thao, T., Bégouën, R. et al. (2018). Tracking in caves. Reading human spoor in ice age caves with San hunters. In: R.F. Puckett & K. Ikeya (Eds.), *Research and activism among Kalahari San today. Ideas, challenges, and debates*. Yubunsha Co., Osaka, 103–128.
- Liebenberg, L.W. (1990). *The art of tracking. The origin of science*. David Philip, Claremont.
- Lockley, M.G., Meldrum, D.J. & Kim, J.Y. (2016). Major events in hominin evolution. In: M.G. Mángano & L.A. Buatois (Eds.), *The trace-fossil record of major evolutionary events. Volume 2: Mesozoic and Cenozoic*. Springer Nature, Dordrecht, 411–448.
- Martin, R. (1928). *Lehrbuch der Anthropologie in systematischer Darstellung mit besonderer Berücksichtigung der anthropologischen Methoden für Studierende Ärzte und Forschungsreisende*. Fischer, Jena.

- Masao, F. T., Ichumbaki, E. B., Cherin, M., Barili, A., Boschian, G., Iurino, D. A. et al. (2016). New footprints from Laetoli (Tanzania) provide evidence for marked body size variation in early hominins. *eLife*.
- Matzig, D. N., Hussain, S. T. & Riede, F. (2021). Design Space Constraints and the Cultural Taxonomy of European Final Palaeolithic Large Tanged Points: A Comparison of Typological, Landmark-Based and Whole-Outline Geometric Morphometric Approaches. *Journal of Paleolithic Archaeology* 4(4): 27.
- Maynard, D. W. (2005). Social Actions, Gestalt Coherence, and Designations of Disability: Lessons from and about Autism. *Social Problems* 52: 499–524.
- Mayoral, E., Díaz-Martínez, I., Duveau, J., Santos, A., Ramírez, A. R., Morales, J. A. et al. (2021). Tracking late Pleistocene Neandertals on the Iberian coast. *Scientific Reports* 11 (1): 4103.
- McClymont, J. & Crompton, R. H. (2021). Repetition Without Repetition. A Comparison of the Laetoli G1, Ileret, Namibian Holocene and Modern Human Footprints Using Pedobarographic Statistical Parametric Mapping. In: A. Pastoors & T. Lenssen-Erz (Eds.), *Reading prehistoric human tracks. Methods and material*. Springer Nature, Cham, 41–66.
- McLaren, D., Fedje, D., Dyck, A., Mackie, Q., Gauvreau, A. & Cohen, J. (2018). Terminal Pleistocene epoch human footprints from the Pacific coast of Canada. *PLoS ONE* 13 (3): e0193522.
- McLaren, D., Mackie, Q. & Fedje, D. (2021). Experimental Re-creation of the Depositional Context in Which Late Pleistocene Tracks Were Found on the Pacific Coast of Canada. In: A. Pastoors & T. Lenssen-Erz (Eds.), *Reading prehistoric human tracks. Methods and material*. Springer Nature, Cham, 91–100.
- Ortega Martínez, A. I. & Martín Merino, M. Á. (2013). *Cuevas de Ojo Guareña. Una visión de la mano del Grupo Espeleológico Edelweiss*. Gráficas Dosbi, Burgos.
- Ortega Martínez, A. I. & Martín Merino, M. Á. (2019). Investigaciones en torno a las Galerías de las Huellas de Ojo Guareña (Merindad de Sotoscueva, Burgos) tras 50 años de su descubrimiento. *Cubia* 23: 22–31.
- Ortega Martínez, A. I., Ruiz, F., Martín Merino, M. Á., Benito-Calvo, A., Vidal, M., Bermejo, L. et al. (2021). Prehistoric Human Tracks in Ojo Guareña Cave System (Burgos, Spain). The Sala and Galerías de las Huellas. In: A. Pastoors & T. Lenssen-Erz (Eds.), *Reading prehistoric human tracks. Methods and material*. Springer Nature, Cham, 317–344.
- Ortega-Martínez, A. I., Martín-Merino, M. Á. & García Díez, M. (2020). Palaeolithic creation and later visits of symbolic spaces: radiocarbon AMS dating and cave art in the Sala de las Pinturas in Ojo Guareña (Burgos, Spain). *Archaeological and Anthropological Sciences* 12 (10).
- Panofsky, E. (1962). *Studien zur Ikonologie. Humanistische Themen in der Kunst der Renaissance*. DuMont, Köln.
- Pastoors, A. & Lenssen-Erz, T. (2020). Tracking in Caves: Indigenous Ichnology. In: C. L. Smith (Ed.), *Encyclopedia of Global Archaeology*. Springer, Cham, 1–6.
- Pastoors, A., Lenssen-Erz, T., Breuckmann, B., Ciquae, T., Kxunta, I., Rieke-Zapp, D. et al. (2017). Experience based reading of Pleistocene human footprints in Pech-Merle. *Quaternary International* 430 A: 155–162.
- Pastoors, A., Lenssen-Erz, T., Ciquae, T., Kxunta, I., Thao, T., Bégouën, R. et al. (2015). Tracking in Caves. Experience based reading of Pleistocene human footprints in French caves. *Cambridge Archaeological Journal* 25 (3): 551–564.
- Pastoors, A., Lenssen-Erz, T., Ciquae, T., Kxunta, I., Thao, T., Bégouën, R. et al. (2021). Episodes of magdalenian hunter-gatherers in the upper gallery of Tuc d'Audoubert (Ariège, France). In: A. Pastoors & T. Lenssen-Erz (Eds.), *Reading prehistoric human tracks. Methods and material*. Springer Nature, Cham, 211–250.
- Piontek, J. & Vančata, V. (2012). Transition to Agriculture in Central Europe. Body Size and Body Shape amongst the First Farmers. *Interdisciplinaria Archaeologica* 3 (1): 23–42.
- Polanyi, M. (1966). The logic of tacit inference. *Philosophy* 41 (155): 1–18.
- R Core Team. (2022). R: A language and environment for statistical computing. <https://www.r-project.org>.
- Reimer, P. J., Austin, W. E. N., Bard, E., Bayliss, A., Blackwell, P. G., Bronk Ramsey, C. et al. (2020). The IntCal20 Northern Hemisphere Radiocarbon Age Calibration Curve (0–55 cal kBP). *Radiocarbon* 62 (4): 725–757.
- Robbins, L. M. (1985). *Footprints. Collection, Analysis, and Interpretation*. Charles C. Thomas, Springfield.
- Roberts, G. (2009). Ephemeral, subfossil mammalian, avian and hominid footprints within Flandrian sediment exposures at Formby Point, Sefton Coast, North West England. *Ichnos* 16 1-2: 33–48.
- Stander, Ph., Ghau, //, Tsisaba, D., #oma, // & /ui, / (1997). Tracking and the interpretation of spoor: a scientifically sound method in ecology. *Journal of Zoology* 242: 329–341.
- Todorovic, D. (2008). Gestalt principles Scholarpedia (3): 5345.
- Topinard, P. (1876). *L'Anthropologie*. Reinwald, Paris.
- Vries, A. de & Ripley, B. D. (2022). gg dendro: Create Dendrograms and Tree Diagrams Using „ggplot2“. <https://CRAN.R-project.org/package=ggdendro>.
- Wagemans, J., Elder, J. H., Kubovy, M., Palmer, S. E., Peterson, M. A., Singh, M. et al. (2012a). A Century of Gestalt Psychology in Visual Perception I. Perceptual Grouping and Figure-Ground Organization. *Psychological Bulletin* 138 (6): 1172–1217.
- Wagemans, J., Feldman, J., Gepshtein, S., Kimchi, R., Pomerantz, J. R., Helm, P. A. van der et al. (2012b). A Century of Gestalt Psychology in Visual Perception II. Conceptual and Theoretical Foundations. *Psychological Bulletin* 138 (6): 1218–1252.
- Ward, J. H. (1963). Hierarchical Grouping to Optimize an Objective Function. *Journal of the American Statistical Association* 58(301): 236–244.
- Webb, D., Bernardo, D. V. & Hermenegildo, T. (2006a). Evaluating and improving footprint measurement. Orientation and lengths. *Anthropologie* 44 (3): 269–280.
- Webb, S. (2021). An Echo from a Footprint. A Step Too Far. In: A. Pastoors & T. Lenssen-Erz (Eds.), *Reading prehistoric human tracks. Methods and material*. Springer Nature, Cham, 397–412.
- Webb, S., Cupper, M. L. & Robins, R. (2006b). Pleistocene human footprints from the Willandra Lakes, southeastern Australia. *Journal of Human Evolution* 50 (4): 405–413.
- Wen, G., Pan, X., Jiang, L. & Wen, J. (2010). Modeling Gestalt laws for classification. In: F. Sun, Y. Wang, J. Lu, B. Zhang, W. Kinsner, & L. A. Zadeh (Eds.), *Proceedings of the 9th International Conference on Cognitive Informatics*. IEEE Computer Society Press, Los Alamitos, 914–918.
- Wertheimer, M. (1923). Untersuchungen zur Lehre von der Gestalt. II. *Psychologische Forschung* 2: 301–350.
- Wong, P. B. Y., Van Coeverden Groot, P. de, Fekken, C., Smith, H., Pages, M. & Boag, P. T. (2011). Interpretation of Polar Bear (*Ursus maritimus*) Tracks by Inuit Hunters: Inter-rater Reliability and Inferences Concerning Accuracy. *The Canadian Field-Naturalist* 125: 140–153.
- Wörgötter, F., Krüger, N., Pugeault, N., Calow, D., Lappe, M., Pauwles, K. et al. (2004). Early cognitive vision: Using Gestalt-laws for task-independent, active image-processing. *Natural Computing* 3: 293–321.
- Zhu, S.-C. (1999). Embedding Gestalt Laws in Markov Random Fields – a theory for shape modeling and perceptual organization. *IEEE Transactions on Pattern Analysis and Machine Intelligence* 21 (11): 1170–1187.

## Inhalt - Contents

### Central German Lower and Middle Palaeolithic assemblages. An overview of technocomplexes supported by flake analysis

*Mitteldeutsche Inventare des Alt- und Mittelpaläolithikums. Ein Überblick über die Technokomplexe auf der Grundlage einer Analyse der Abschlüge*

**Thomas WEBER .....7-22**

### The osseous industry of the LGM site Kammern-Grubgraben (Lower Austria), excavations 1985–1994, and its position within the European Late Upper Palaeolithic

*Die organische Industrie der LGM-Fundstelle Kammern-Grubgraben (Niederösterreich), Grabungen 1985–1994, und ihre Position innerhalb des Späten Jungpaläolithikums in Europa*

**Sebastian J. PFEIFER, Kerstin PASDA, Marc HÄNDEL, Andreas MAIER & Thomas EINWÖGERER.....23-46**

### More on the Magdalenian in Thuringia – A re-investigation of the faunal remains from Teufelsbrücke

*Mehr vom Magdalénien aus Thüringen - Eine Neubearbeitung der Faunenreste aus der Teufelsbrücke*

**Werner MÜLLER & Clemens PASDA .....47-71**

### Spätpaläolithikum und Mesolithikum des Felsdaches „Zigeunerfels“ (Lkr. Sigmaringen, Deutschland)

*Late Palaeolithic and Mesolithic of the rockshelter-site "Zigeunerfels" (Sigmaringen, Germany)*

**Tina Katharina HORNAUER-JAHNKE & Stefan WETTENGL .....73-96**

### Reading Mesolithic Human Tracks with a Multi-Method Approach in the Paul Ambert gallery of Aldène cave (Cessero, Hérault, France)

*Lesen mesolithischer Fußabdrücke in der Paul Ambert Galerie der Höhle Aldène (Cessero, Hérault, Frankreich) mit einem multi-methodischen Ansatz*

**Andreas PASTOORS, Tilman LENSSEN-ERZ<sup>†</sup>, Tsamgao CIQAE, /Ui KXUNTA, Thui THAO, Philippe GALANT, Marcel WEIß & Thorsten UTHMEIER .....97-138**